



Model 132A36

**Micro ICP® pressure sensor, 140 mV/psi, 1/2-20 mtg thd (for high frequency
Installation and Operating Manual**

**For assistance with the operation of this product,
contact PCB Piezotronics, Inc.**

**Toll-free: 800-828-8840
24-hour SensorLine: 716-684-0001
Fax: 716-684-0987
E-mail: info@pcb.com
Web: www.pcb.com**



The information contained in this document supersedes all similar information that may be found elsewhere in this manual.

Total Customer Satisfaction – PCB Piezotronics guarantees Total Customer Satisfaction. If, at any time, for any reason, you are not completely satisfied with any PCB product, PCB will repair, replace, or exchange it at no charge. You may also choose to have your purchase price refunded in lieu of the repair, replacement, or exchange of the product.

Service – Due to the sophisticated nature of the sensors and associated instrumentation provided by PCB Piezotronics, user servicing or repair is not recommended and, if attempted, may void the factory warranty. Routine maintenance, such as the cleaning of electrical connectors, housings, and mounting surfaces with solutions and techniques that will not harm the physical material of construction, is acceptable. Caution should be observed to insure that liquids are not permitted to migrate into devices that are not hermetically sealed. Such devices should only be wiped with a dampened cloth and never submerged or have liquids poured upon them.

Repair – In the event that equipment becomes damaged or ceases to operate, arrangements should be made to return the equipment to PCB Piezotronics for repair. User servicing or repair is not recommended and, if attempted, may void the factory warranty.

Calibration – Routine calibration of sensors and associated instrumentation is

recommended as this helps build confidence in measurement accuracy and acquired data. Equipment calibration cycles are typically established by the users own quality regimen. When in doubt about a calibration cycle, a good “rule of thumb” is to recalibrate on an annual basis. It is also good practice to recalibrate after exposure to any severe temperature extreme, shock, load, or other environmental influence, or prior to any critical test.

PCB Piezotronics maintains an ISO-9001 certified metrology laboratory and offers calibration services, which are accredited by A2LA to ISO/IEC 17025, with full traceability to N.I.S.T. In addition to the normally supplied calibration, special testing is also available, such as: sensitivity at elevated or cryogenic temperatures, phase response, extended high or low frequency response, extended range, leak testing, hydrostatic pressure testing, and others. For information on standard recalibration services or special testing, contact your local PCB Piezotronics distributor, sales representative, or factory customer service representative.

Returning Equipment – *Following these procedures will insure that your returned materials are handled in the most expedient manner.* Before returning any equipment to PCB Piezotronics, contact your local distributor, sales representative, or factory customer service representative to obtain a Return

Materials Authorization (RMA) Number. This RMA number should be clearly marked on the outside of all package(s) and on the packing list(s) accompanying the shipment. A detailed account of the nature of the problem(s) being experienced with the equipment should also be included inside the package(s) containing any returned materials.

A Purchase Order, included with the returned materials, will expedite the turn-around of serviced equipment. It is recommended to include authorization on the Purchase Order for PCB to proceed with any repairs, as long as they do not exceed 50% of the replacement cost of the returned item(s). PCB will provide a price quotation or replacement recommendation for any item whose repair costs would exceed 50% of replacement cost, or any item that is not economically feasible to repair. For routine calibration services, the Purchase Order should include authorization to proceed and return at current pricing, which can be obtained from a factory customer service representative.

Warranty – All equipment and repair services provided by PCB Piezotronics, Inc. are covered by a limited warranty against defective material and workmanship for a period of one year from date of original purchase. Contact

PCB for a complete statement of our warranty. Expendable items, such as batteries and mounting hardware, are not covered by warranty. Mechanical damage to equipment due to improper use is not covered by warranty. Electronic circuitry failure caused by the introduction of unregulated or improper excitation power or electrostatic discharge is not covered by warranty.

Contact Information – International customers should direct all inquiries to their local distributor or sales office. A complete list of distributors and offices can be found at www.pcb.com. Customers within the United States may contact their local sales representative or a factory customer service representative. A complete list of sales representatives can be found at www.pcb.com. Toll-free telephone numbers for a factory customer service representative, in the division responsible for this product, can be found on the title page at the front of this manual. Our ship to address and general contact numbers are:

PCB Piezotronics, Inc.
3425 Walden Ave.
Depew, NY 14043 USA
Toll-free: (800) 828-8840
24-hour SensorLineSM: (716) 684-0001
Website: www.pcb.com
E-mail: info@pcb.com

1.0 INTRODUCTION

132 Series Microsensors are small, piezoelectric pressure sensors featuring extremely fast response for measurement of short wavelength pressure pulses. The short time constant of some models filters off the longer duration portion of pressure pulses, allowing differentiation of consecutive pressure pulses.

132 Series Microsensors contain integrated ICP[®] circuit amplifiers which operate as source followers and provide very high-frequency response. These micro-integrated circuit amplifiers convert the high-impedance voltage from the crystals into low-impedance voltage of less than 100 ohms.

Output from the microsensors may be coupled directly into oscilloscopes, recorders and A to D converters. Power to operate the IC amplifier and the output signal are conducted over a single conductor, two-wire cable with the ground serving as signal return. Special low-noise cables are not required. The calibrated mV/psi output of these microsensors is not attenuated nor is noise appreciably increased by the cable.

2.0 DESCRIPTION

132 Series Microsensors feature small diameter pressure-sensing surfaces incorporating very small (< 1 mm) piezoelectric sensing elements. The small size of the sensing elements imparts extremely fast response time to the microsensors.

The charge generated by deflection of the piezoelectric element when subjected to shock pressures creates a voltage on the input capacitance at the gate of the microsensor ICP[®] amplifier. The amplifier, in conjunction with the source element, transforms the input into a low-impedance output signal of equal amplitude. The DC bias that exists on the signal lead is removed from the output signal by a coupling capacitor in the power supply. Resistors in the internal ICP[®] amplifiers of the microsensors set the internal discharge time constant, which

determines the low-frequency response of the microsensors. (Refer to General Guide to ICP[®] Instrumentation, G-0001, for complete details.)

Below are the available configurations for the 132 Series Microsensors.

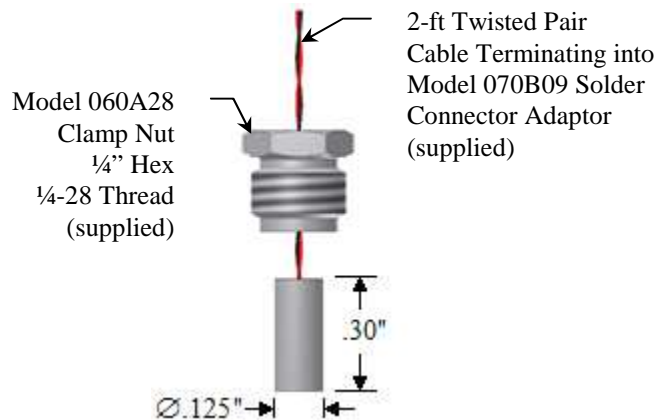

**Model 132A31 Time-of-Arrival
ICP[®] Microsensor**

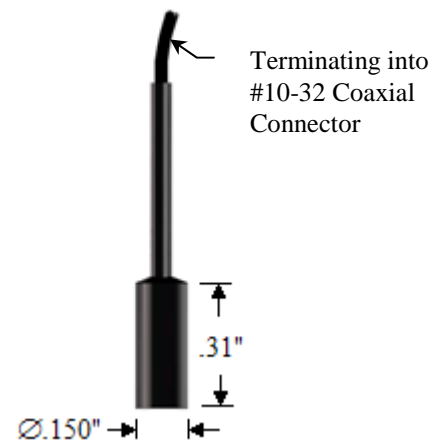

Model 132A32

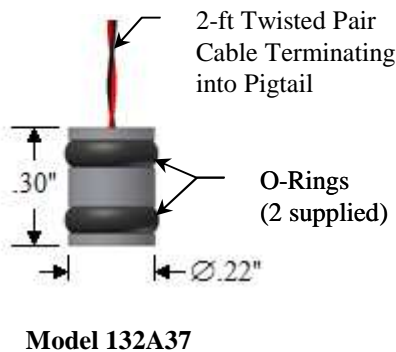
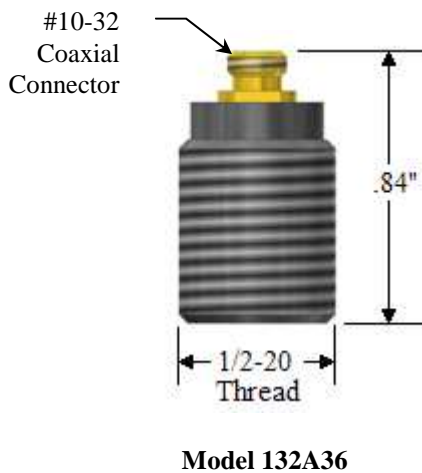
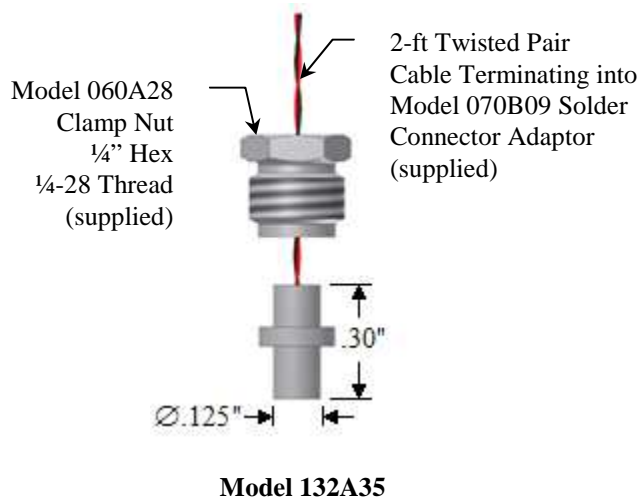

3.0 INSTALLATION

Refer to the installation drawing for details. If the microsensors are to be subjected to pressures beyond their specified range, be sure to use backing nuts to prevent the sensors from backing out of their mounting ports. (Thread adaptors are available from PCB to facilitate mounting.)

Connect the microsensors to an ICP® power supply. Use standard two-conductor cable between the sensor and the ICP® power unit.

Next, connect the power unit to a readout device, e.g., oscilloscope, recorder or high-speed A to D converter.

4.0 OPERATION

Switch the ICP® power unit on and observe reading of bias-monitoring voltmeter on front panel of power unit.

If indicator is in green section of indicator panel, the IC amplifier is providing proper bias (normally +11 VDC), cable connections are normal and the system is ready to operate.

If the needle moves to the red area of the fault monitor meter, output is zero and a short is indicated. The short could be located in the amplifier cable connectors or in the power unit.

If the pointer moves into the yellow area of the fault monitor meter, an open circuit is indicated with full power supply voltage. An open circuit could be the result of a faulty amplifier, an open cable or open connectors.

Allow the sensor to thermally stabilize for about one minute. A signal drift may occur when the output cable is connected to the readout instrument.

The drift occurs during charging of the coupling capacitor in the power unit. The signal will stabilize in several minutes.

4.1 OPERATION BEYOND RANGE SPECIFICATION

Because 132 Series Microsensors can be installed using RTV-like potting materials to hold them in place, maximum pressure specifications are given to prevent the sensors from being extruded from the mounting holes. Static or slow dynamic overpressures are more apt to cause a problem than a short dynamic shock pulse. Use of backing nuts will minimize the possibility of a problem.

The microsensors are capable of responding to dynamic overpressures up to ten times the specified range. The output will be “clipped” (look flat-topped on the readout) after about 10 volts.

The initial rise of the output will be accurate up to the point of clipping. This can allow for an accurate time-of-arrival measurement, even though the peak pressure cannot be measured.

5.0 CALIBRATION

A shock tube is used to calibrate the microsensors.

6.0 MAINTENANCE AND REPAIR

Except for repair of wires, the microsensors are not field-repairable. In case of serious malfunction, contact the PCB at (888) 684-0011.

It is well to observe the following precautions in using the microsensors:

1. Do not exceed specified pressure levels without proper mounting.
2. Do not subject microsensors to temperatures exceeding 174 °F (79 °C).
3. Do not apply voltage to sensors without current-limiting diodes or other current protection. (PCB ICP[®] power supplies feature proper voltage and current protection.)
4. Do not apply more than 20 mA of current to the microsensors.

Model Number 132A36	ICP® PRESSURE SENSOR		Revision: K ECN #: 19746
Performance	ENGLISH	SI	OPTIONAL VERSIONS
Measurement Range	50 psi	345 kPa	Optional versions have identical specifications and accessories as listed for the standard model except where noted below. More than one option may be used. M - Metric Mount W - Water Resistant Cable
Sensitivity (± 30 %)	140 mV/psi	20.3 mV/kPa	
Maximum Pressure (Dynamic)	800 psi	5515 kPa	
Resolution	1 mpsi	0.007 kPa	
Resonant Frequency	≥ 1000 kHz	≥ 1000 kHz	
Rise Time (Incident)	≤ 3 μ sec	≤ 3 μ sec	
Rise Time (Reflected)	≤ 0.5 μ sec	≤ 0.5 μ sec	
Low Frequency Response (-5 %)	11 kHz	11 kHz	
Environmental			
Temperature Range (Operating)	0 to +175 °F	-18 to +79 °C	
Electrical			NOTES: [1] Rise time in air at Mach 1
Output Polarity (Positive Pressure)	Positive	Positive	SUPPLIED ACCESSORIES: Model 061A30 Spanner Wrench, 2 Pin (1)
Discharge Time Constant (at room temp)	≥ .000045 sec	≥ .000045 sec	
Excitation Voltage	20 to 30 VDC	20 to 30 VDC	
Constant Current Excitation	2 to 20 mA	2 to 20 mA	
Output Impedance	≤ 100 ohms	≤ 100 ohms	
Output Bias Voltage	8 to 14 VDC	8 to 14 VDC	ICP® Pressure Sensor Specifications
Physical			Entered: <i>PLS</i> Engineer: <i>RF</i> Sales: <i>DPC</i> Approved: <i>MEM</i> Spec Number:
Sensing Element	Ceramic	Ceramic	Date: <i>4/27/04</i> Date: <i>4/27/04</i> Date: <i>4/28/04</i> Date: <i>4/28/04</i> 1911
Housing Material	Delrin	Delrin	
Sealing	Epoxy	Epoxy	
Electrical Connector	10-32 Coaxial Jack	10-32 Coaxial Jack	
Weight	0.095 oz	2.7 gm	
<i>All specifications are at room temperature unless otherwise specified. In the interest of constant product improvement, we reserve the right to change specifications without notice.</i>			
ICP® is a registered trademark of PCB Group, Inc.			
PCB PIEZOTRONICS™ PRESSURE DIVISION 3425 Walden Avenue, Depew, NY 14043			Phone: 716-684-0001 Fax: 716-686-9129 E-Mail: pressure@pcb.com

1900

PCB Piezotronics Inc. claims proprietary rights in the information disclosed hereon. Neither it nor any reproduction thereof will be disclosed to others without written consent of PCB Piezotronics Inc.

APPLICATION

NEXT ASS'Y	USED ON	VAR

REVISIONS

REV	DESCRIPTION	ECN	DATE	APP'D
A	UPDATED AND REDRAWN	12273	8/23/00	<i>PL</i>

SPANNER WRENCH HOLES

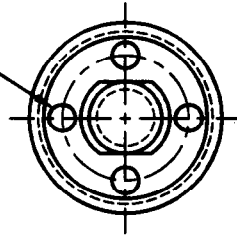

ELECTRICAL CONNECTOR
CO-AXIAL 10-32 UNF-2A

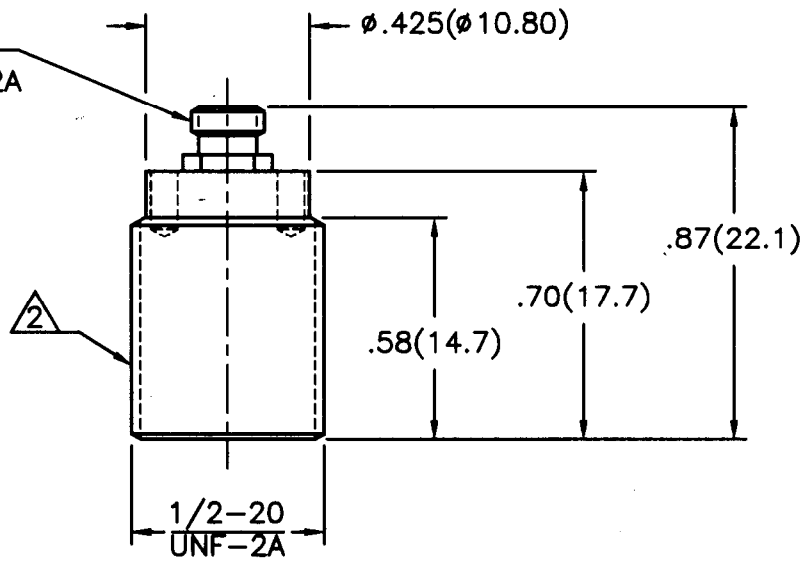

MOUNTING HOLE PREPARATION

DRILL $\phi .453(\phi 11.51)$
THRU
TAP 1/2-20 UNF-2B
THRU

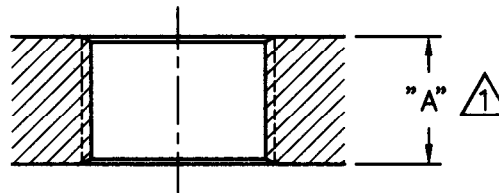

2 USE OF TEFLON TAPE IS RECOMMENDED WHEN MOUNTING ADAPTOR.

1 "A" DIMENSION TO SUIT USER REQUIREMENTS.

UNLESS SPECIFIED TOLERANCES		DRAWN	<i>SMZ</i>	<i>8/23/00</i>	MFG	<i>ROA</i>	<i>8/23/00</i>	 3425 WALDEN AVE. DEPEW, NY 14043 (716) 684-0001 EMAIL: SALES@PCB.COM
DIMENSIONS IN INCHES	DIMENSIONS IN MILLIMETERS (IN PARENTHESIS)	CHK'D	<i>SM</i>	<i>8/23/00</i>	ENGR	<i>LAB</i>	<i>8/23/00</i>	
DECIMALS XX ±.01 XXX ±.005	DECIMALS XX ±0.3 XXX ±0.13	APP'D	<i>PL</i>	<i>8/23/00</i>	SALES	<i>Jmm</i>	<i>8/23/00</i>	
ANGLES ±2 DEGREES	ANGLES ±2 DEGREES	TITLE						CODE IDENT. NO.
FILLETS AND RADII .003 - .005	FILLETS AND RADII (0.07 - 0.13)	INSTALLATION DRAWING MODEL 132A36 DYNAMIC PRESSURE SENSOR						52681
DD011 REV. B 03/13/98		SCALE: 2X						DWG. NO. 1900
							SHEET 1 OF 1	