



Model 123A22

**Rocket motor ICP® pressure sensor, 3000 psi, 1 mV/psi, Helium bleed,
Installation and Operating Manual**

**For assistance with the operation of this product,
contact PCB Piezotronics, Inc.**

**Toll-free: 800-828-8840
24-hour SensorLine: 716-684-0001
Fax: 716-684-0987
E-mail: info@pcb.com
Web: www.pcb.com**



The information contained in this document supersedes all similar information that may be found elsewhere in this manual.

Total Customer Satisfaction – PCB Piezotronics guarantees Total Customer Satisfaction. If, at any time, for any reason, you are not completely satisfied with any PCB product, PCB will repair, replace, or exchange it at no charge. You may also choose to have your purchase price refunded in lieu of the repair, replacement, or exchange of the product.

Service – Due to the sophisticated nature of the sensors and associated instrumentation provided by PCB Piezotronics, user servicing or repair is not recommended and, if attempted, may void the factory warranty. Routine maintenance, such as the cleaning of electrical connectors, housings, and mounting surfaces with solutions and techniques that will not harm the physical material of construction, is acceptable. Caution should be observed to insure that liquids are not permitted to migrate into devices that are not hermetically sealed. Such devices should only be wiped with a dampened cloth and never submerged or have liquids poured upon them.

Repair – In the event that equipment becomes damaged or ceases to operate, arrangements should be made to return the equipment to PCB Piezotronics for repair. User servicing or repair is not recommended and, if attempted, may void the factory warranty.

Calibration – Routine calibration of sensors and associated instrumentation is

recommended as this helps build confidence in measurement accuracy and acquired data. Equipment calibration cycles are typically established by the users own quality regimen. When in doubt about a calibration cycle, a good “rule of thumb” is to recalibrate on an annual basis. It is also good practice to recalibrate after exposure to any severe temperature extreme, shock, load, or other environmental influence, or prior to any critical test.

PCB Piezotronics maintains an ISO-9001 certified metrology laboratory and offers calibration services, which are accredited by A2LA to ISO/IEC 17025, with full traceability to N.I.S.T. In addition to the normally supplied calibration, special testing is also available, such as: sensitivity at elevated or cryogenic temperatures, phase response, extended high or low frequency response, extended range, leak testing, hydrostatic pressure testing, and others. For information on standard recalibration services or special testing, contact your local PCB Piezotronics distributor, sales representative, or factory customer service representative.

Returning Equipment – *Following these procedures will insure that your returned materials are handled in the most expedient manner.* Before returning any equipment to PCB Piezotronics, contact your local distributor, sales representative, or factory customer service representative to obtain a Return

Materials Authorization (RMA) Number. This RMA number should be clearly marked on the outside of all package(s) and on the packing list(s) accompanying the shipment. A detailed account of the nature of the problem(s) being experienced with the equipment should also be included inside the package(s) containing any returned materials.

A Purchase Order, included with the returned materials, will expedite the turn-around of serviced equipment. It is recommended to include authorization on the Purchase Order for PCB to proceed with any repairs, as long as they do not exceed 50% of the replacement cost of the returned item(s). PCB will provide a price quotation or replacement recommendation for any item whose repair costs would exceed 50% of replacement cost, or any item that is not economically feasible to repair. For routine calibration services, the Purchase Order should include authorization to proceed and return at current pricing, which can be obtained from a factory customer service representative.

Warranty – All equipment and repair services provided by PCB Piezotronics, Inc. are covered by a limited warranty against defective material and workmanship for a period of one year from date of original purchase. Contact

PCB for a complete statement of our warranty. Expendable items, such as batteries and mounting hardware, are not covered by warranty. Mechanical damage to equipment due to improper use is not covered by warranty. Electronic circuitry failure caused by the introduction of unregulated or improper excitation power or electrostatic discharge is not covered by warranty.

Contact Information – International customers should direct all inquiries to their local distributor or sales office. A complete list of distributors and offices can be found at www.pcb.com. Customers within the United States may contact their local sales representative or a factory customer service representative. A complete list of sales representatives can be found at www.pcb.com. Toll-free telephone numbers for a factory customer service representative, in the division responsible for this product, can be found on the title page at the front of this manual. Our ship to address and general contact numbers are:

PCB Piezotronics, Inc.
3425 Walden Ave.
Depew, NY 14043 USA
Toll-free: (800) 828-8840
24-hour SensorLineSM: (716) 684-0001
Website: www.pcb.com
E-mail: info@pcb.com

**OPERATION MANUAL FOR
HELIUM BLEED WATER-COOLED
PRESSURE SENSORS**
Models 123A, 123A21, 123A22, 123A23, & 123A24

1.0 INTRODUCTION

The series of sensors described in this guide is designed to measure dynamic pressures in intense thermal environments typified by rocket engine combustion chambers.

These sensors feature acceleration-compensated piezoelectric pressure probes mounted in a helium bleed adaptor with water cooling.

The helium gas, applied from a 1500 psi source, is metered by a built-in orifice and flows around the probe body and out the passage of the adaptor head of the probe diaphragm. The helium gas flowing out the passage protects the sensor diaphragm from the hot gasses as well as increasing the natural frequency of the passage by a factor of approximately three to one.

2.0 DESCRIPTION

The Model 123A contains a one pC/psi pressure probe (sensor) and is designed to be used with electrostatic charge amplifiers such as the PCB Model 462A.

The Models 123A21, A22, A23, and A24 contain built-in impedance converter electronics circuits which convert the high-impedance voltage from the quartz crystal to a low-impedance voltage signal that can be fed directly into most common indicating or recording instruments.

The 123A series sensors contain a 10 micro helium filter contained in a fitting threaded onto the helium input tube. The purpose of this filter is to prevent particles in the helium supply from plugging the metering orifice.

The outer body of this series is 17-4 PH hardened stainless steel and features a ceramic-coated tip for protection against erosion by hot gasses when the sensor is flush-mounted directly in combustion chambers.

The probes in all models are electrically ground isolated from the outer housing.

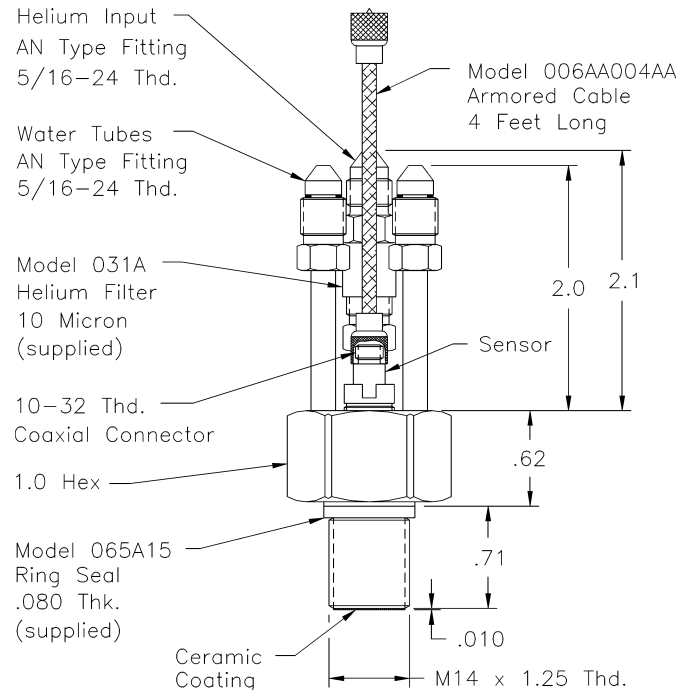

Series 123A: Water- Cooled & Helium Bleed Rocket Motor, ICP® and Charge Sensors

NOTE: The sensor probe in this series is factory installed at a precise depth in the outer body. Do not attempt removal of this probe. Contact the factory should any questions or problems arise concerning the sensor probe.

3.0 INSTALLATION

Prepare mounting port in accordance with instructions on installation drawing 123-1010-90 or 123-1210-90.

Inspect the mounting port for burrs and tool marks at the seal surface.

Use recommended mounting torque when installing sensors. Do not overtorque as damage to seal surface could result.

**OPERATION MANUAL FOR
HELIUM BLEED WATER-COOLED
PRESSURE SENSORS
Models 123A, 123A21, 123A22, 123A23, & 123A24**

NOTE: When attaching helium supply hose, do not torque hose fitting through helium tube on sensor. Back up fitting with wrench on 3/8 hex on helium hose fitting. (Refer to note 3 on installation drawing.)

Especially in the presence of high vibration, support helium supply tubes by clamping to rigid surfaces with adequate strain relief loop to avoid stressing helium tube on sensor.

Follow the same procedures and apply similar precautions when installing the water supply and drain hoses. Either water tube may be used as the inlet tube. Use at least a 50 psi source of clean water for cooling.

For charge output Model 123A, connect 4 ft. cable to charge amplifier and switch to "LONG" time constant position and check for drift.

Clean cable connections with Tryclor[®] or equivalent solvent to restore insulation resistance.

It is good practice to depress ground button (or place switch in "GND" position) on the charge amplifier while attaching input cables to the amplifier. This will prevent spurious charges which may accumulate on sensors and cables from blowing out the input circuitry of the charge amplifier.

Since the charge output sensors are susceptible to decreased insulation resistance, use care to keep cable connections clean by use of shrink tubing wherever possible.

The Models 123A21, A22, A23 and A24 Sensors use low-output impedance probes (ICP[®]) and will not require the insulation resistance cautions previously described for Model 123A.

Connect the sensor cable to the appropriate ICP[®] power unit and check the front panel monitor meter to check cable connections and internal amplifier.

Consult Guide G-0001B, "General Guide to ICP[®] Instrumentation" for installation and usage hints for ICP[®] instruments.

4.0 OPERATION

4.1 CHARGE OUTPUT MODEL 123A

For the Model 123A charge output, it is only necessary to select the proper range on the charge amplifier and proceed with the measurement.

The probe sensitivity is approximately 1.0 pC/psi. (The exact sensitivity is given on the calibration certificate supplied with each instrument.)

EXAMPLE: The dynamic pressure expected is 500 psi and the desired output voltage for this pressure is 1 volt.

Simply set the range switch of the charge amplifier to 500 units per volt and dial the standardization pot to the exact sensor sensitivity at 500 psi (from calibration graph).

The system will then yield exactly 1 volt for 500 psi of input pressure (dynamic).

4.2 TIME CONSTANT

During in-place calibration static methods (dead weight tester) may be used in a drift-free system by placing the charge amplifier in "LONG TC" position.

However, during actual use, the TC mode switch should be in "SHORT" position for two reasons.

Often times, the dynamic pressure being measured exists superimposed upon a higher static level. The short TC position will allow the effect of this static level to zero out quickly without effect on the dynamic level indicated.

Also, the influx of large amounts of thermal energy, as in rocket combustion measurements, can cause the sensor to generate spurious transient outputs of considerable magnitude. Using the charge amplifier on "SHORT" TC alleviates this problem by shunting these longer term charge outputs to ground while measuring the faster dynamic pressure pulses.

**OPERATION MANUAL FOR
HELIUM BLEED WATER-COOLED
PRESSURE SENSORS
Models 123A, 123A21, 123A22, 123A23, & 123A24**

4.3 OPERATION - ICP[®] MODELS 123A21, A22, A23, and A24

Consult Guide G-0001B for a complete description of the low-impedance concept in instrumentation.

All PCB power units designed for ICP[®] use contain built-in fault monitor meters to aid in locating circuit faults (shorts or opens) and to identify normal operation of the miniature impedance-converting amplifier built into the sensor.

Do not attempt to apply voltage directly to the input pin of the sensor from any other power source. The input current must be limited to 20 mA maximum and the input voltage must not be higher than 28 VDC. Consult the factory if it is desired to build a power unit rather than to use one of those available from PCB.

The Models 123A21, A22, A23, and A24 are identical except for sensitivity.

The Model 123A21 has a sensitivity of 20 mV/psi which gives a full-scale range (for +5 V out) of 250 psi.

The Model 123A22 has a sensitivity of 1.0 (for +3 V out) mV/psi and a full-scale range of 3000 psi.

The Model 123A23 has a sensitivity of 0.5 mV/psi and a full-scale range of 10,000 psi.

The Model 123A24 has a sensitivity of 5.0 mV/psi and a full-scale range of 1000 psi.

NOTE: Full-scale range is limited by the helium source pressure. The helium source pressure must be at least twice the peak combustion pressure (static plus dynamic) to be measured, but not more than about 10 times the lowest pressure. This is true for all models, charge or ICP[®].

5.0 CALIBRATION

5.1 CHARGE MODEL 123A

To calibrate this model, install in pressure port of dead weight tester and apply various static pressures, recording corresponding outputs at each pressure of interest.

Discharge the charge amplifier before each reading and return pressure to zero before each new pressure input. Use the charge amplifier on "LONG" time constant and keep cables and connections clean to avoid drift. A DC digital voltmeter is ideal for readout during calibration.

NOTE: The helium tube must be plugged with a pressure-tight seal before attempting to calibrate to avoid losing pressure through the helium tube.

If a hydraulic calibration system is used, be sure to remove all traces of oil from the diaphragm passage after calibration. Pneumatic systems are preferred for calibration.

5.2 ICP[®] MODELS 123A21, A22, A23 & A24

Because of the shorter time constants built into these models, static calibration methods are much more difficult to use. Pressures must be applied rapidly and readout must be made with fast recording devices such as light beam oscillographs or storage oscilloscopes.

A pneumatic (compressed air or hydrogen) system with quick opening valve and reference gage is an excellent method of calibrating these sensors.

To take full advantage of the constant built into the sensor, use a DC-coupled power unit such as the PCB Model 484B06.

**OPERATION MANUAL FOR
HELIUM BLEED WATER-COOLED
PRESSURE SENSORS
Models 123A, 123A21, 123A22, 123A23, & 123A24**

MAINTENANCE

The sealed construction and miniature size of these sensors make field repair impractical.

The helium filter element should be cleaned should the flow rate decrease. Remove the element and ultrasonically agitate in solvent for 15 minutes, then dry.

Should the orifice become plugged, back pressure the orifice by applying air pressure to diaphragm end of sensor with filter off and helium tube vented to atmosphere.

The only maintenance possible on the probe is maintaining of insulation resistance of the Model 123A Probe/Cable Assembly. Clean connectors with suitable solvent and dry.

Contact factory for assistance should problems arise.

®ICP is a registered trademark of PCB Piezotronics

Model Number
123A22

ICP® PRESSURE SENSOR

Revision: H
ECN #: 29109

	ENGLISH	SI	
Performance			
Measurement Range(for ± 3V output)	3 kpsi	20,685 kPa	
Sensitivity(± 15 %)	1.0 mV/psi	0.145 mV/kPa	
Maximum Pressure	5 kpsi	34,475 kPa	
Resolution	100 mpsi	0.689 kPa	[2]
Resonant Frequency	≥ 25 kHz	≥ 25 kHz	[3]
Rise Time(Reflected)	≤ 20 μ sec	≤ 20 μ sec	[3]
Low Frequency Response(-5 %)	0.001 Hz	0.001 Hz	
Non-Linearity	≤ 1.0 % FS	≤ 1.0 % FS	[4]
Environmental			
Acceleration Sensitivity	≤ 0.002 psi/g	≤ 0.0014 kPa/(m/s ²)	
Temperature Range(Operating)	-100 to +250 °F	-73 to +121 °C	[1]
Temperature Coefficient of Sensitivity	≤ 0.03 %/°F	≤ 0.054 %/°C	
Maximum Flash Temperature	10,000 °F	5538 °C	
Maximum Shock	10,000 g pk	98,070 m/s ² pk	
Electrical			
Output Polarity(Positive Pressure)	Positive	Positive	
Discharge Time Constant(at room temp)	≥ 500 sec	≥ 500 sec	
Excitation Voltage	20 to 30 VDC	20 to 30 VDC	
Constant Current Excitation	2 to 20 mA	2 to 20 mA	
Output Impedance	≤ 100 ohm	≤ 100 ohm	
Output Bias Voltage	8 to 12 VDC	8 to 12 VDC	
Physical			
Housing Material	17-4 Stainless Steel	17-4 Stainless Steel	
Diaphragm	Invar	Invar	
Sealing	Epoxy	Epoxy	
Electrical Connector	Integral Cable	Integral Cable	
Weight	4.23 oz	120 gm	
Helium Flow Rate(at 1,500 psi)	40 scf/hr	1.13 m ³ /hr	
Cable Length	4 ft	1.2 m	
Water Flow Rate(at 50 psi)	1.2 gal/min	4.5 L/min	

OPTIONAL VERSIONS
Optional versions have identical specifications and accessories as listed for the standard model except where noted below. More than one option may be used.

NOTES:

- [1] Applies to internal amplifier, not to external housing.
- [2] Typical.
- [3] With helium flow.
- [4] Zero-based, least-squares, straight line method.
- [5] See PCB Declaration of Conformance PS023 for details.

SUPPLIED ACCESSORIES:

- Model 065A15 Seal, .624" OD x .553" ID x .080", brass (3)
- Model 070A08 Cable adaptor (micro 10-32 jack to BNC jack) (1)

Entered: <i>BLS</i>	Engineer: <i>RF</i>	Sales: <i>RWM</i>	Approved: <i>BM</i>	Spec Number:
Date: <i>7/16/08</i>	Date: <i>7/16/08</i>	Date: <i>7/16/08</i>	Date: <i>7/16/08</i>	5018



All specifications are at room temperature unless otherwise specified.
In the interest of constant product improvement, we reserve the right to change specifications without notice.

ICP® is a registered trademark of PCB Group, Inc.

PCB PIEZOTRONICS™
PRESSURE DIVISION
3425 Walden Avenue, Depew, NY 14043

Phone: 716-684-0001
Fax: 716-686-9129
E-Mail: pressure@pcb.com

123-1210-90

PCB Piezotronics Inc. claims proprietary rights in the information disclosed hereon. Neither it nor any reproduction thereof will be disclosed to others without written consent of PCB Piezotronics Inc.

APPLICATION

NEXT ASS'Y	USED ON	VAR

REVISIONS

REV	DESCRIPTION	ECN	DATE	APP'D
G	REVISED PER ECR	12593	11/06/00	DM11/00
H	ADD FLAG NOTE 4	22945	10/06/05	dm10/05

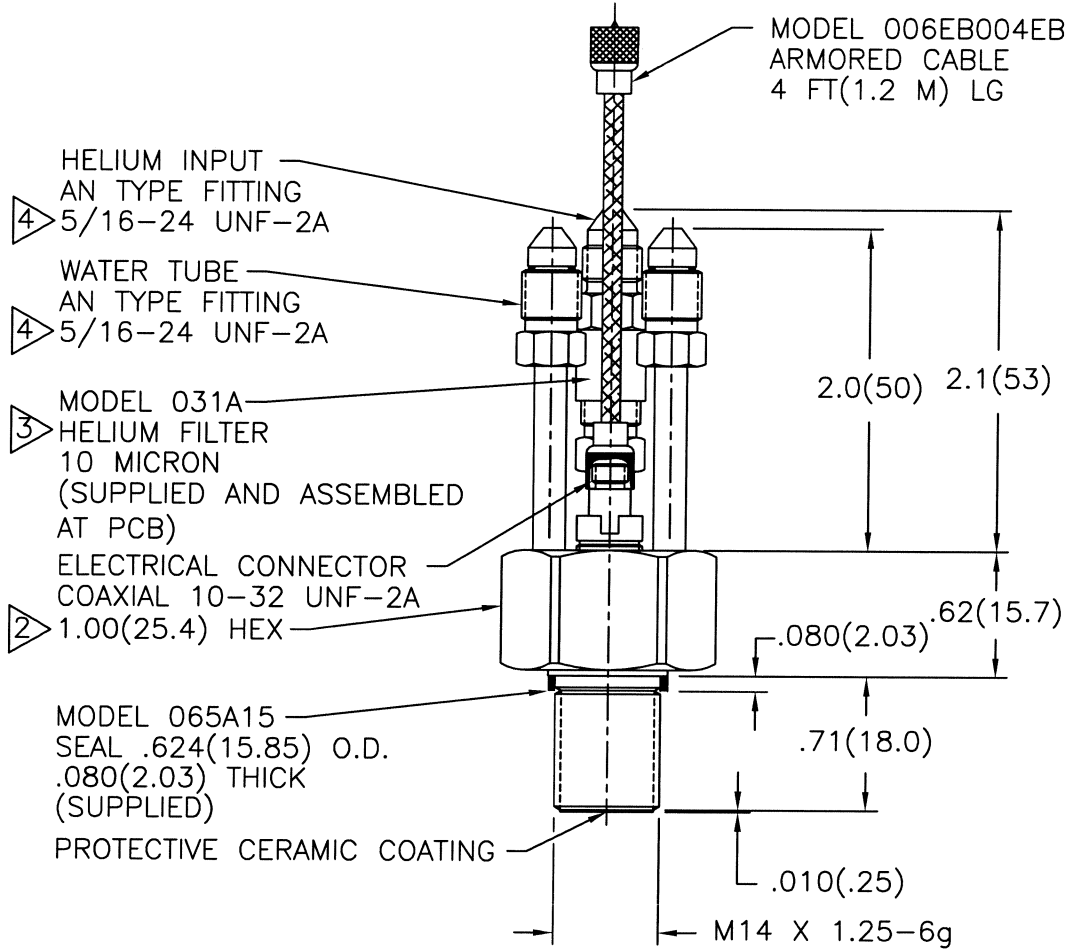

- 4. RECOMMENDED MOUNTING TORQUE : 15-30 INCH POUNDS[1.7-3.4 NEWTON METERS]
- 3. SUPPORT .375(9.53) HEX ON FILTER WHEN ATTACHING LINE TO AVOID DAMAGE TO HELIUM INPUT TUBE.
- 2. RECOMMENDED MOUNTING TORQUE ON 1.00(25.4) HEX 10-15 FOOT POUNDS (13-20 NEWTON METERS).

1.) SEE SHEET TWO FOR MOUNTING HOLE PREPARATION.

UNLESS SPECIFIED TOLERANCES		DRAWN	ECB	10/6/05	MFG	RC	10/18/05	 3425 WALDEN AVE. DEPEW, NY 14043 (716) 684-0001 EMAIL: SALES@PCB.COM
DIMENSIONS IN INCHES	DIMENSIONS IN MILLIMETERS [IN BRACKETS]	CHK'D	DM	10/18/05	ENGR	RF	10/9/05	
DECIMALS XX ±.03 XXX ±.010	DECIMALS X ±0.8 XX ±0.25	APP'D	WEM	10/18/05	SALES	Jmm	10/18/05	
ANGLES ±2 DEGREES	ANGLES ±2 DEGREES	TITLE						SCALE: FULL
FILLET AND RADII .003 - .005	FILLET AND RADII [0.07 - 0.13]	INSTALLATION DRAWING MODELS 123A21, 22, 23, & 24 HELIUM BLEED, WATER COOLED SENSOR						SHEET 1 OF 2
DD011 REV. C 01/21/03								

123-1210-90

PCB Piezotronics Inc. claims proprietary rights in the information disclosed herein. Neither it nor any reproduction thereof will be disclosed to others without written consent of PCB Piezotronics Inc.

APPLICATION

NEXT ASS'Y	USED ON	VAR

REVISIONS

REV	DESCRIPTION	ECN	DATE	APP'D
	- SEE SHEET ONE -			DM 10/05

MOUNTING HOLE PREPARATION:

$\phi .500 [12.70]$
 THRU
 $\sqsupset \phi .625 [\phi 15.88] \triangle 1$
 $X .060 [1.52] \nabla$
 M14 X 1.25-6H
 THRU

MOUNTING HOLE PREPARATION:

$\phi .100 [2.54]$
 THRU
 $\sqsupset \phi .500 [\phi 12.70]$
 $X .810 [20.57] \nabla$
 $\sqsupset \phi .625 [\phi 15.88] \triangle 1$
 $X .060 [1.52] \nabla$
 M14 X 1.25-6H
 $X .720 [18.29] \nabla$

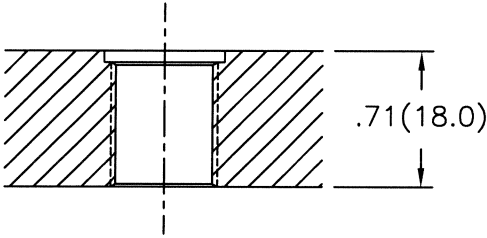

FLUSH MOUNT

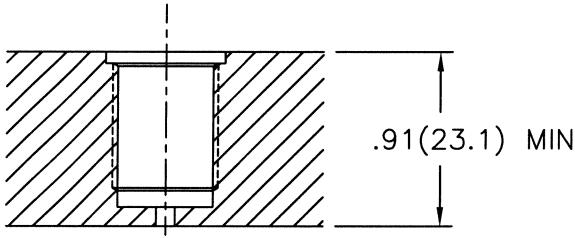

RECESS MOUNT

$\triangle 1$ SEAL SURFACE MUST BE FLAT AND FREE OF TOOL MARKS WITH $63\sqrt{}$ (1.6 $\sqrt{}$) FINISH.

UNLESS SPECIFIED TOLERANCES		DRAWN	ECB	10/05	MFG	RC	10/18/05	 3425 WALDEN AVE. DEPEW, NY 14043 (716) 684-0001 EMAIL: SALES@PCB.COM
DIMENSIONS IN INCHES	DIMENSIONS IN MILLIMETERS [IN BRACKETS]	CHK'D	DM	10/18/05	ENGR	RF	10/7/05	
DECIMALS XX ±.03 XXX ±.010	DECIMALS X ±0.8 XX ±0.25	APP'D	DM	10/18/05	SALES	Jmm	10/11/05	
ANGLES ±2 DEGREES	ANGLES ±2 DEGREES	TITLE						CODE IDENT. NO.
FILLETS AND RADII .003 - .005	FILLETS AND RADII [0.07 - 0.13]	INSTALLATION DRAWING MODELS 123A21, 22, 23, & 24 HELIUM BLEED, WATER COOLED SENSOR						DWG. NO. 123-1210-90
DD011 REV. C 01/21/03								SCALE: FULL SHEET 2 OF 2