



Model 112M362
ICP® Pressure Sensor
Installation and Operating Manual

**For assistance with the operation of this product,
contact PCB Piezotronics, Inc.**

Toll-free: 800-828-8840
24-hour SensorLine: 716-684-0001
Fax: 716-684-0987
E-mail: info@pcb.com
Web: www.pcb.com



The information contained in this document supersedes all similar information that may be found elsewhere in this manual.

Total Customer Satisfaction – PCB Piezotronics guarantees Total Customer Satisfaction. If, at any time, for any reason, you are not completely satisfied with any PCB product, PCB will repair, replace, or exchange it at no charge. You may also choose to have your purchase price refunded in lieu of the repair, replacement, or exchange of the product.

Service – Due to the sophisticated nature of the sensors and associated instrumentation provided by PCB Piezotronics, user servicing or repair is not recommended and, if attempted, may void the factory warranty. Routine maintenance, such as the cleaning of electrical connectors, housings, and mounting surfaces with solutions and techniques that will not harm the physical material of construction, is acceptable. Caution should be observed to insure that liquids are not permitted to migrate into devices that are not hermetically sealed. Such devices should only be wiped with a dampened cloth and never submerged or have liquids poured upon them.

Repair – In the event that equipment becomes damaged or ceases to operate, arrangements should be made to return the equipment to PCB Piezotronics for repair. User servicing or repair is not recommended and, if attempted, may void the factory warranty.

Calibration – Routine calibration of sensors and associated instrumentation is

recommended as this helps build confidence in measurement accuracy and acquired data. Equipment calibration cycles are typically established by the users own quality regimen. When in doubt about a calibration cycle, a good “rule of thumb” is to recalibrate on an annual basis. It is also good practice to recalibrate after exposure to any severe temperature extreme, shock, load, or other environmental influence, or prior to any critical test.

PCB Piezotronics maintains an ISO-9001 certified metrology laboratory and offers calibration services, which are accredited by A2LA to ISO/IEC 17025, with full traceability to N.I.S.T. In addition to the normally supplied calibration, special testing is also available, such as: sensitivity at elevated or cryogenic temperatures, phase response, extended high or low frequency response, extended range, leak testing, hydrostatic pressure testing, and others. For information on standard recalibration services or special testing, contact your local PCB Piezotronics distributor, sales representative, or factory customer service representative.

Returning Equipment – *Following these procedures will insure that your returned materials are handled in the most expedient manner.* Before returning any equipment to PCB Piezotronics, contact your local distributor, sales representative, or factory customer service representative to obtain a Return

Materials Authorization (RMA) Number. This RMA number should be clearly marked on the outside of all package(s) and on the packing list(s) accompanying the shipment. A detailed account of the nature of the problem(s) being experienced with the equipment should also be included inside the package(s) containing any returned materials.

A Purchase Order, included with the returned materials, will expedite the turn-around of serviced equipment. It is recommended to include authorization on the Purchase Order for PCB to proceed with any repairs, as long as they do not exceed 50% of the replacement cost of the returned item(s). PCB will provide a price quotation or replacement recommendation for any item whose repair costs would exceed 50% of replacement cost, or any item that is not economically feasible to repair. For routine calibration services, the Purchase Order should include authorization to proceed and return at current pricing, which can be obtained from a factory customer service representative.

Warranty – All equipment and repair services provided by PCB Piezotronics, Inc. are covered by a limited warranty against defective material and workmanship for a period of one year from date of original purchase. Contact

PCB for a complete statement of our warranty. Expendable items, such as batteries and mounting hardware, are not covered by warranty. Mechanical damage to equipment due to improper use is not covered by warranty. Electronic circuitry failure caused by the introduction of unregulated or improper excitation power or electrostatic discharge is not covered by warranty.

Contact Information – International customers should direct all inquiries to their local distributor or sales office. A complete list of distributors and offices can be found at www.pcb.com. Customers within the United States may contact their local sales representative or a factory customer service representative. A complete list of sales representatives can be found at www.pcb.com. Toll-free telephone numbers for a factory customer service representative, in the division responsible for this product, can be found on the title page at the front of this manual. Our ship to address and general contact numbers are:

PCB Piezotronics, Inc.
3425 Walden Ave.
Depew, NY 14043 USA
Toll-free: (800) 828-8840
24-hour SensorLineSM: (716) 684-0001
Website: www.pcb.com
E-mail: info@pcb.com

**OPERATION MANUAL FOR
ICP® PRESSURE SENSORS
Models 102A02, A05, A07, A09
Models 112A21, A22, A23**

1.0 INTRODUCTION

The series of miniature pressure sensors described by this operating guide is designed for low pressure, high resolution applications and features acceleration compensation.

Uses include monitoring of low pressure hydraulic and pneumatic phenomena in the presence of shock and vibration such as on jet engines, compressors, turbines and other operating machinery, high intensity sound and turbulence measurements, and many other industrial R & D applications.

2.0 DESCRIPTION

This series is comprised of six sensor models having high sensitivities, but differing in mechanical configuration.

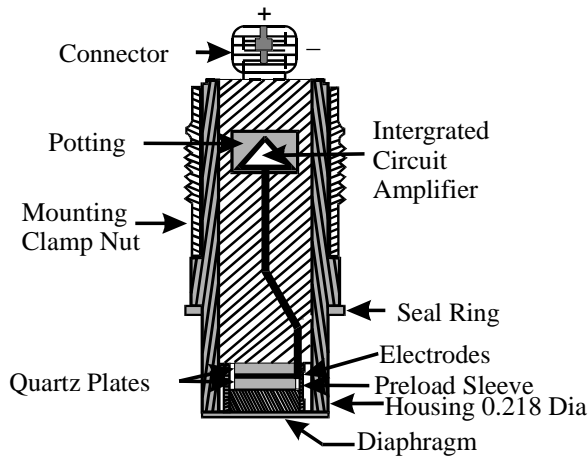

Typical ICP® Probe Style Sensor

Each model utilizes the basic ICP® pressure probe as shown in above figure. The pressure probe consists of the Model 112A high sensitivity acceleration-compensated quartz element and an IC source follower amplifier joined together as an inseparable assembly.

Refer to "General Guide to ICP® Instrumentation" G-0001B for a complete treatment of the ICP® concept.

Models 112A21, 112A22 and 112A23 are in the basic probe configuration as shown in Figure 1, and are installed with a hollow clamp nut with 5/16-24 external threads. The housings of these models are at electrical ground potential.

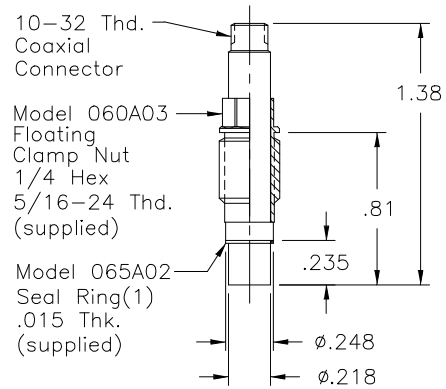

Series 111: Probe Style Sensor

The Model 102A05 utilizes the same basic pressure probe, mounted in a 3/8-24 threaded mounting adaptor with shoulder seal. The probe is assembled into the adaptor at the factory in an "off ground" configuration, i.e., the probe body is electrically insulated from the external mounting adaptor body. Do not attempt to disassemble probe and adaptor.

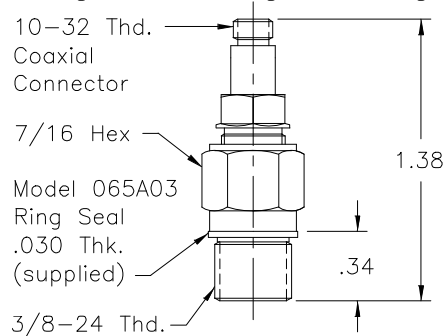

Model 102A05 Thread Mount Design, Ground-Isolated Sensor

**OPERATION MANUAL FOR
ICP® PRESSURE SENSORS
Models 102A02, A05, A07, A09
Models 112A21, A22, A23**

Models 102A02, 102A07, and 102A09 utilize the same inner probe design but in a 3/8-24 threaded adaptor with floating clamp nut to allow adjustment of diaphragm depth where it is necessary to adapt to various wall thicknesses. These models are supplied only in low pressure (100 and 50 psi) versions and are also "off ground".

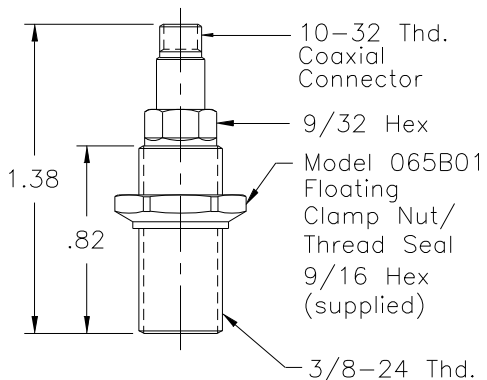

102A's: Thread Mount with Floating Clamp Nut, Ground-Isolated Sensor

3.0 INSTALLATION

This manual contains outline and installation information for your specific model in this series. Prepare mounting ports in accordance with the installation drawing for the specific model, paying particular attention to sealing surfaces. These surfaces must be smooth and free from chatter marks, nicks and other irregularities which could preclude a pressure-tight seal.

Seals are provided with each sensor and should always be used. Extra seals for all standard models are in stock at the factory. Replace seals when they become unserviceable.

In some cases, e.g., where flash temperatures such as those generated by combustion processes are present, it may be necessary to thermally insulate the diaphragm to minimize spurious signals generated by these effects.

Common black vinyl electrical tape has been found to be an effective insulating material in many cases. One or more layers may be used across the end of the diaphragm without affecting response or sensitivity.

A silicone rubber coating approximately .010" thick has also been proven effective in many applications. General Electric RTV type 106 silicone rubber is recommended. Apply the rubber coating and allow to cure in accordance with the manufacturer's instructions.

Although ICP® sensors have low output impedance and in general are not affected by moisture, in extreme environments it is good practice to protect cable connections with shrink tubing.

It is not necessary to use low-noise coaxial cable with this sensor series. In fact, a Model 070A09 solder connector adaptor that allows the use of ordinary two-wire cable is desired.

4.0 OPERATION

It is only necessary to supply the sensor with a 2 to 20 mA constant current at +20 to +30 VDC through a current-regulating diode or equivalent circuit. (See Guide G-0001B for powering and signal utilization information pertaining to all ICP® instrumentation).

Most of the signal conditioners manufactured by PCB have an adjustable current feature allowing a choice of input currents from 2 to 20 mA. In general, for lowest noise (best resolution) choose the low current ranges and for driving long cables (to several thousand feet) use the higher current, up to 20 mA maximum.

To operate system using a PCB signal conditioner:

1. Switch power on.
2. Wait several minutes for the IC amplifier to turn on and stabilize.
3. Proceed with measurements.

4.1 OPERATING CONSIDERATION FOR MODEL 112A23

The Model 112A23 features a low-noise amplifier which, based on a peak-to-peak broadband noise factor of 50 μ V, results in a resolution of .001 psi.

**OPERATION MANUAL FOR
ICP® PRESSURE SENSORS
Models 102A02, A05, A07, A09
Models 112A21, A22, A23**

Defined for practical purposes as the minimum readout signal, the resolution is based on the sensitivity of 50 mV/psi and a low noise amplifier of 50 μ V peak noise.

Thus, $50 \mu\text{V}/50\text{mV} = .001$ psi resolution

The output bias voltage of the Model 112A23 is 5.0 volts, half the bias voltage of most PCB pressure sensors. This will cause the bias monitor meter on PCB power supplies to read at the low end of the green band.

5.0 POLARITY

This sensor series produces a positive-going output voltage for increasing pressure input.

6.0 LOW FREQUENCY RESPONSE

The low frequency response of an ICP® system is determined by:

1. The discharge time constant of the sensor, and,
2. If AC-coupled at power unit, the coupling time constant.

Consult Section 7.0 in Guide G-0001B for detailed explanation of low frequency characteristics of ICP® instruments.

7.0 CALIBRATION

Piezoelectric sensors are dynamic devices, but static calibration methods may be employed if discharge time constants are sufficiently long. Generally, static methods are not employed below several hundred seconds discharge time constant.

To employ static methods, directly couple the sensor to the DVM readout using a T-connector from the XD4R jack or use the Model 484B in the "calibrate" mode. Apply pressure with dead weight tester and take readings quickly. Release pressure after each calibration point.

For the shorter discharge time constant series, a rapid pressure step must be generated by a pneumatic pressure pulse calibrator or dead weight tester and readout is by recorder or storage oscilloscope.

PCB offers a complete recalibration service. Consult factory for details.

**OPERATION MANUAL FOR
ICP® PRESSURE SENSORS
Models 102A02, A05, A07, A09
Models 112A21, A22, A23**

8.0 MAINTENANCE

The miniature size sealed construction precludes field maintenance. Should service be required, return unit to factory with note describing problem.

®ICP is a registered trademark of PCB Piezotronics

Model Number 112M362	ICP® PRESSURE SENSOR		Revision: NR ECN #: 41958										
Performance Measurement Range(for ±5V output) Useful Overrange(for ± 10V output) Sensitivity(± 15 %) Maximum Pressure Resolution Resonant Frequency Rise Time Low Frequency Response(-5 %) Non-Linearity	ENGLISH 50 psi 100 psi 100 mV/psi 500 psi 0.001 psi ≥ 250 kHz ≤ 2.0 µ sec 0.50 Hz ≤ 1.0 % FS	SI 345 kPa 690 kPa 14.5 mV/kPa 3450 kPa 0.007 kPa ≥ 250 kHz ≤ 2.0 µ sec 0.50 Hz ≤ 1.0 % FS	OPTIONAL VERSIONS Optional versions have identical specifications and accessories as listed for the standard model except where noted below. More than one option may be used.										
Environmental Acceleration Sensitivity Temperature Range(Operating) Temperature Coefficient of Sensitivity Maximum Flash Temperature Maximum Shock	≤ 0.002 psi/g -100 to +275 °F ≤ 0.06 %/°F 3000 °F 20,000 g pk	≤ 0.0014 kPa/(m/s ²) -73 to +135 °C ≤ 0.108 %/°C 1650 °C 196,000 m/s ² pk	NOTES: [1] For +10 volt output, minimum 24 VDC supply voltage required. Negative 10 volt output may be limited by output bias. [2] Zero-based, least-squares, straight line method.										
Electrical Discharge Time Constant(at room temp) Excitation Voltage Constant Current Excitation Output Impedance Output Bias Voltage	≥ 1.0 sec 22 to 30 VDC 2 to 20 mA <200 Ohm 8 to 14 VDC	≥ 1.0 sec 22 to 30 VDC 2 to 20 mA <200 Ohm 8 to 14 VDC	SUPPLIED ACCESSORIES: Model 070A05 Cable feed-thru connector (micro 10-32 jack to 10-32 jack) (1)										
Physical Sensing Geometry Sensing Element Housing Material Diaphragm Sealing Electrical Connector Weight Cable Termination Cable Type Cable Length	Compression Quartz 17-4 Stainless Steel Invar Welded Hermetic 10-32 Coaxial Jack 0.17 oz 10-32 Coaxial Jack 031 Twisted Pair 16 in	Compression Quartz 17-4 Stainless Steel Invar Welded Hermetic 10-32 Coaxial Jack 4.9 gm 10-32 Coaxial Jack 031 Twisted Pair 41 cm	<table border="1"> <tr> <td>Entered: AP</td> <td>Engineer: JDK</td> <td>Sales: RWM</td> <td>Approved: BAM</td> <td>Spec Number:</td> </tr> <tr> <td>Date: 9/23/2013</td> <td>Date: 9/23/2013</td> <td>Date: 9/23/2013</td> <td>Date: 9/23/2013</td> <td>55523</td> </tr> </table>	Entered: AP	Engineer: JDK	Sales: RWM	Approved: BAM	Spec Number:	Date: 9/23/2013	Date: 9/23/2013	Date: 9/23/2013	Date: 9/23/2013	55523
Entered: AP	Engineer: JDK	Sales: RWM	Approved: BAM	Spec Number:									
Date: 9/23/2013	Date: 9/23/2013	Date: 9/23/2013	Date: 9/23/2013	55523									
All specifications are at room temperature unless otherwise specified. In the interest of constant product improvement, we reserve the right to change specifications without notice. ICP® is a registered trademark of PCB Group, Inc.			 Phone: 716-684-0001 Fax: 716-684-0987 E-Mail: info@pcb.com 3425 Walden Avenue, Depew, NY 14043										

55522

PCB Piezotronics Inc. claims proprietary rights in the information disclosed hereon. Neither it nor any reproduction thereof will be disclosed to others without the written consent of PCB Piezotronics Inc.

REVISIONS		
REV	DESCRIPTION	DIN
NR	RELEASED TO DRAFTING	41958

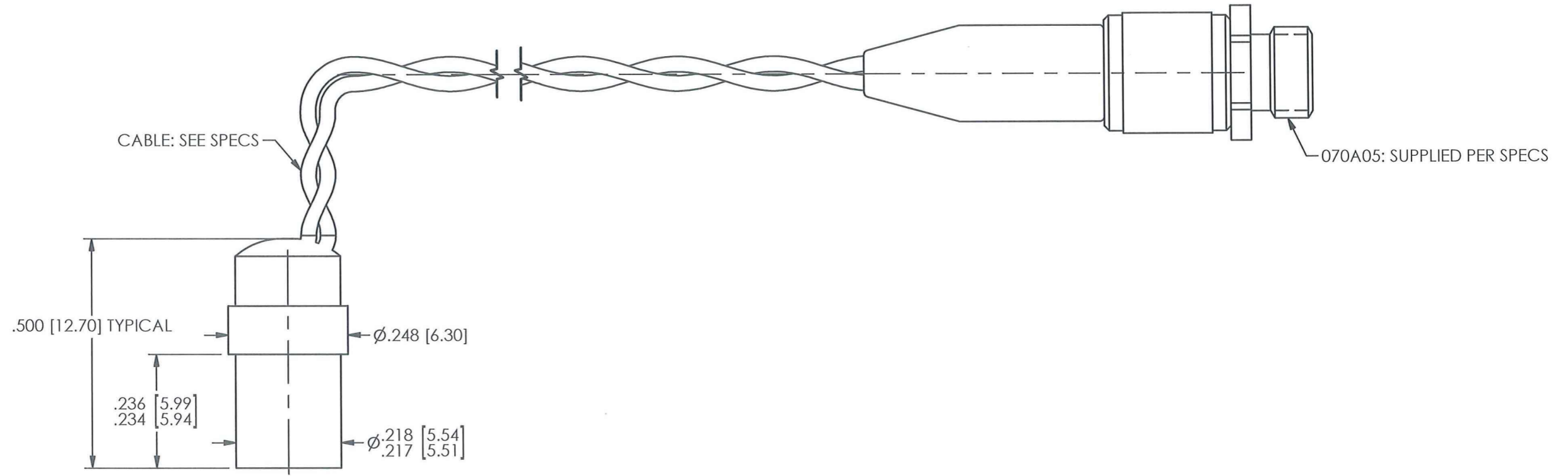

MOUNTING HOLE PREPARATION:

- 1 Ø.221±.002 [5.61±.05] THRU
- 2 L-Ø.250^{+.003}/_{-.000} [3.65^{+.08}/_{-.00}] TO DEPTH SHOWN

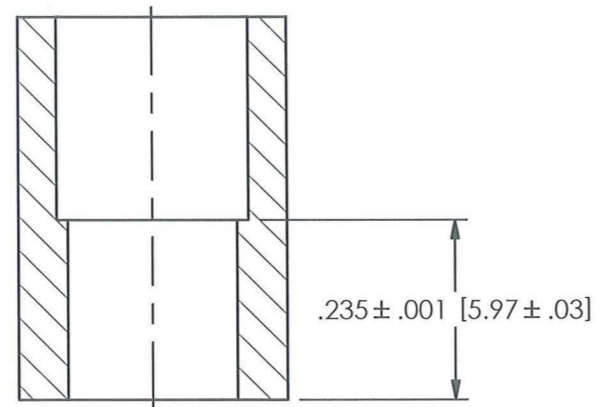

- 2 MOUNTING SURFACE SHOULD BE FLAT TO WITHIN .001 [0.03] TIR OVER Ø.272 [6.91] WITH A MINIMUM 63 [1.6] FINISH FOR BEST RESULTS.
- 1 DRILL PERPENDICULAR TO MOUNTING SURFACE TO WITHIN ±1°.

UNLESS OTHERWISE SPECIFIED TOLERANCES ARE:		DRAWN	CHECKED	ENGINEER	 3425 WALDEN AVE. DEPEW, NY 14043 (716) 684-0001 E-MAIL: sales@pcb.com
DIMENSIONS IN INCHES	DIMENSIONS IN MILLIMETERS [IN BRACKETS]	JDM	9/20/13	JDK	
DECIMALS XX ±.01 XXX ±.005	DECIMALS X ±0.3 XX ±0.13	TITLE			CODE IDENT. NO. 52681
ANGLES ± 2 DEGREES	ANGLES ± 2 DEGREES	INSTALLATION DRAWING MODEL 112M362 PRESSURE SENSOR			DWG. NO. 55522
FILLETS AND RADII .003 - .005	FILLETS AND RADII 0.07 - 0.13				SCALE: 4X SHEET 1 OF 1

improves: 07-01 0/22/2012