



**Model 8159-0012A**

**1 CHANNEL STRAIN GAGE SENSOR SIGNAL CONDITIONER**

**Installation and Operating Manual**

**For assistance with the operation of this product,  
contact PCB Piezotronics, Inc.**

**Toll-free: 800-828-8840  
24-hour SensorLine: 716-684-0001  
Fax: 716-684-0987  
E-mail: [info@pcb.com](mailto:info@pcb.com)  
Web: [www.pcb.com](http://www.pcb.com)**



## Repair and Maintenance

PCB guarantees Total Customer Satisfaction through its “Lifetime Warranty Plus” on all Platinum Stock Products sold by PCB and through its limited warranties on all other PCB Stock, Standard and Special products. Due to the sophisticated nature of our sensors and associated instrumentation, **field servicing and repair is not recommended and, if attempted, will void the factory warranty.**

Beyond routine calibration and battery replacements where applicable, our products require no user maintenance. Clean electrical connectors, housings, and mounting surfaces with solutions and techniques that will not harm the material of construction. Observe caution when using liquids near devices that are not hermetically sealed. Such devices should only be wiped with a dampened cloth—never saturated or submerged.

In the event that equipment becomes damaged or ceases to operate, our Application Engineers are here to support your troubleshooting efforts 24 hours a day, 7 days a week. Call or email with model and serial number as well as a brief description of the problem.

## Calibration

Routine calibration of sensors and associated instrumentation is necessary to maintain measurement accuracy. We recommend calibrating on an annual basis, after exposure to any extreme environmental influence, or prior to any critical test.

PCB Piezotronics is an ISO-9001 certified company whose calibration services are accredited by A2LA to ISO/IEC 17025, with full traceability to SI through N.I.S.T. In addition to our standard calibration services, we also offer specialized tests, including: sensitivity at elevated or cryogenic temperatures, phase response, extended high or low frequency response, extended range, leak testing, hydrostatic pressure testing, and others. For more information, contact your local PCB Piezotronics distributor, sales representative, or factory customer service representative.

## Returning Equipment

If factory repair is required, our representatives will provide you with a Return Material Authorization (RMA) number, which we use to reference any information you have already provided and expedite the repair process. This number should be clearly marked on the outside of all returned package(s) and on any packing list(s) accompanying the shipment.

## Contact Information

PCB Piezotronics, Inc.  
3425 Walden Ave.  
Depew, NY14043 USA  
Toll-free: (800) 828-8840  
24-hour SensorLine: (716) 684-0001  
General inquiries: [info@pcb.com](mailto:info@pcb.com)  
Repair inquiries: [rma@pcb.com](mailto:rma@pcb.com)

For a complete list of distributors, global offices and sales representatives, visit our website, [www.pcb.com](http://www.pcb.com).

## Safety Considerations

This product is intended for use by qualified personnel who recognize shock hazards and are familiar with the precautions required to avoid injury. While our equipment is designed with user safety in mind, the protection provided by the equipment may be impaired if equipment is used in a manner not specified by this manual.

Discontinue use and contact our 24-Hour Sensorline if:

- Assistance is needed to safely operate equipment
- Damage is visible or suspected
- Equipment fails or malfunctions

For complete equipment ratings, refer to the enclosed specification sheet for your product.

## Definition of Terms and Symbols

The following symbols may be used in this manual:



### DANGER

Indicates an immediate hazardous situation, which, if not avoided, may result in death or serious injury.

**CAUTION**

Refers to hazards that could damage the instrument.

**NOTE**

Indicates tips, recommendations and important information. The notes simplify processes and contain additional information on particular operating steps.

**The following symbols may be found on the equipment described in this manual:**



This symbol on the unit indicates that high voltage may be present. Use standard safety precautions to avoid personal contact with this voltage.



This symbol on the unit indicates that the user should refer to the operating instructions located in the manual.



This symbol indicates safety, earth ground.



PCB工业监视和测量设备 - 中国RoHS2公布表

PCB Industrial Monitoring and Measuring Equipment - China RoHS 2 Disclosure Table

部件名称	有害物质					
	铅 (Pb)	汞 (Hg)	镉 (Cd)	六价铬 (Cr(VI))	多溴联苯 (PBB)	多溴二苯醚 (PBDE)
住房	0	0	0	0	0	0
PCB板	X	0	0	0	0	0
电气连接器	0	0	0	0	0	0
压电晶体	X	0	0	0	0	0
环氧	0	0	0	0	0	0
铁氟龙	0	0	0	0	0	0
电子	0	0	0	0	0	0
厚膜基板	0	0	X	0	0	0
电线	0	0	0	0	0	0
电缆	X	0	0	0	0	0
塑料	0	0	0	0	0	0
焊接	X	0	0	0	0	0
铜合金/黄铜	X	0	0	0	0	0
本表格依据 SJ/T 11364 的规定编制。						
0：表示该有害物质在该部件所有均质材料中的含量均在 GB/T 26572 规定的限量要求以下。						
X：表示该有害物质至少在该部件的某一均质材料中的含量超出 GB/T 26572 规定的限量要求。						
铅是欧洲RoHS指令2011/65/ EU附件三和附件四目前由于允许的豁免。						

CHINA RoHS COMPLIANCE

Component Name	Hazardous Substances					
	Lead (Pb)	Mercury (Hg)	Cadmium (Cd)	Chromium VI Compounds (Cr(VI))	Polybrominated Biphenyls (PBB)	Polybrominated Diphenyl Ethers (PBDE)
Housing	O	O	O	O	O	O
PCB Board	X	O	O	O	O	O
Electrical Connectors	O	O	O	O	O	O
Piezoelectric Crystals	X	O	O	O	O	O
Epoxy	O	O	O	O	O	O
Teflon	O	O	O	O	O	O
Electronics	O	O	O	O	O	O
Thick Film Substrate	O	O	X	O	O	O
Wires	O	O	O	O	O	O
Cables	X	O	O	O	O	O
Plastic	O	O	O	O	O	O
Solder	X	O	O	O	O	O
Copper Alloy/Brass	X	O	O	O	O	O

This table is prepared in accordance with the provisions of SJ/T 11364.

O: Indicates that said hazardous substance contained in all of the homogeneous materials for this part is below the limit requirement of GB/T 26572.

X: Indicates that said hazardous substance contained in at least one of the homogeneous materials for this part is above the limit requirement of GB/T 26572.

Lead is present due to allowed exemption in Annex III or Annex IV of the European RoHS Directive 2011/65/EU.

**TABLE OF CONTENTS**

<b><u>Section</u></b>		<b><u>Page</u></b>
1.0	DESCRIPTION	2
2.0	INSTALLATION	3
3.0	WIRING	4
4.0	SWITCH DEFINITION	8
5.0	FUNCTION DEFINITIONS	9
6.0	OPERATING INSTRUCTIONS	10
7.0	CALIBRATION INSTRUCTIONS	12
8.0	OPTIONS	15

<b><u>Figure</u></b>		<b><u>Page</u></b>
1	Series 8159 Front Panel View	2
2	Series 8159 Rear Panel View	3
3	Panel Mounting Cut-Out Dimensions	3
4	Transducer Wiring	4
5	Input/Output (I/O) Wiring	5
6	Location of Jumpers and Potentiometers (Top View)	6
7	SW1 Switch Settings	6
8	Location of 115/230 VAC Jumper (Bottom View)	6
9	Location of RCAL Resistor	7
10	Front Panel Switches	7
11	Transducer Connections	13
12	Program Menu Diagram	16

**MANUAL NUMBER: 23865**  
**MANUAL REVISION: J**  
**DIN. NUMBER: 49289**

**1.0 DESCRIPTION**

The Series 8159 is a microprocessor-based digital indicator capable of interfacing directly to low level strain gage transducers. An internal, high gain, fully differential amplifier and a 4-½ digit analog-to-digital converter combine to accurately digitize the input signal. A 5V @ 60mA or 10V @ 120mA, short circuit protected, transducer excitation supply is also provided. A +/- 10VDC analog output signal, with a 1kHz bandwidth, comes standard with the instrument. A 4-20 mA analog output signal is also standard with the instrument. A front panel RCAL switch provides a convenient calibration feature. TARE and CALIBRATION are easily performed via front panel pushbuttons.

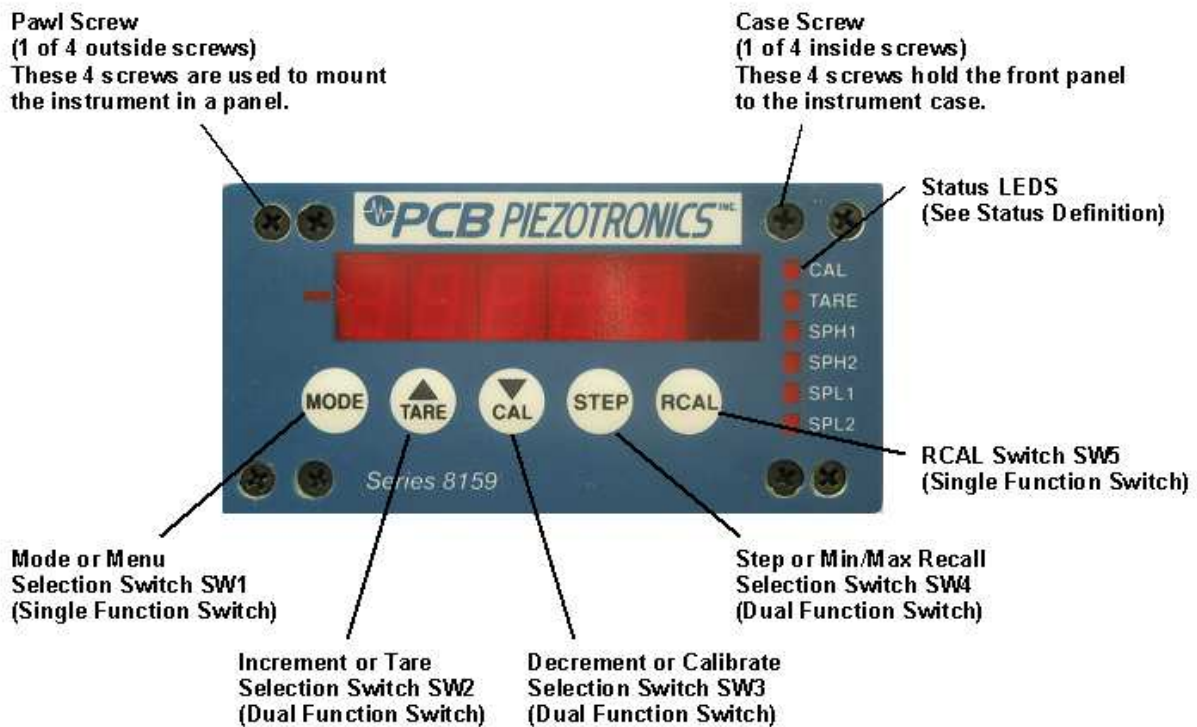

Figure 1 - Series 8159 Front Panel View

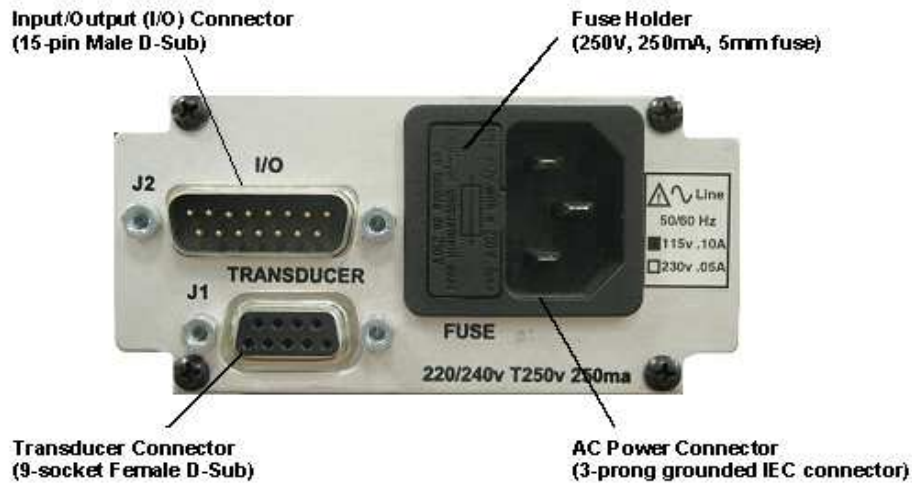

Figure 2 - Series 8159 Rear Panel View

## 2.0 INSTALLATION

The Series 8159 enclosure is designated for panel mounting in a 1/8 DIN cutout. The cutout dimensions are shown below.

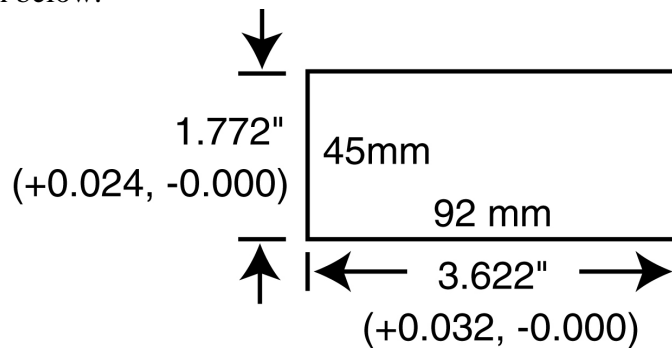



Figure 3 - Panel Mounting Cutout Dimensions

To panel mount the 8159, perform the following steps:

1. Rotate the four pawl screws (outside screws in each corner) several turns counter-clockwise to retract the pawls. Make sure the pawls retract enough to clear the back of the mounting panel. The pawls may be retracted to accommodate panel thickness up to 0.25 inches (6.35mm).
2. Insert the instrument into the panel cutout.
3. Position the pawls so that their elongated dimension overlaps the panel cutout, then tighten the screws. Do not over-tighten.
4. Installation complete.

### 3.0 WIRING

Reference Figures 4 and 5 for TRANSDUCER and INPUT/OUTPUT (I/O) wiring information. Power is applied with a 3-prong AC power cord. The instrument is protected by a 250V, 250mA fast acting 5mm fuse. The fuse holder is an integral part of the input power connector. A spare fuse is provided in the fuse holder. Internal solder jumpers are provided to allow 115VAC or 230VAC operation (Reference Figure 8).

 **Warning:** Remove AC power to the 8159 meter before changing the fuse.

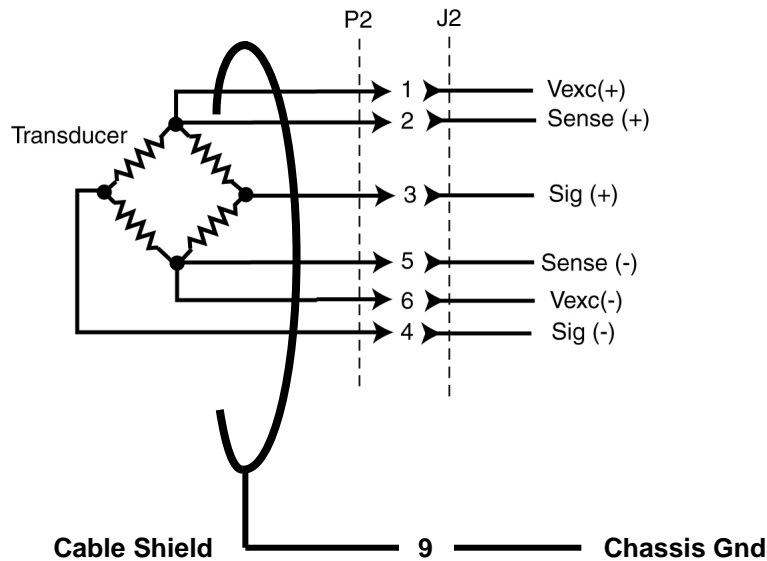



 The cable shield must connect directly to an RF/EMI rated connector hood instead of pin 9. The shield must make a 360 degree bond to the connector hood at the cable entry.

Figure 4 - Transducer Wiring

It is recommended that the sense leads be used with cable lengths longer than 20 feet. The excitation voltage is then sensed and regulated at the transducer for optimum shunt calibration. Consult factory for cable lengths over 100 feet.

 **Warning:** Remove AC power to the 8159 meter before removing any enclosure panels or making any internal adjustments or changes.

To enable or disable the sense lead setting, perform the following:

1. Open the back panel of the meter case by removing the four (4) screws located in the corners of the panel face.
2. Expose the connector circuit board located on the back of the back panel.

**NOTE:** For newer units, the boards use R2 and R3 instead of JP2 and JP3.

3. Remove the solder jumpers from JP2 and JP3 to ENABLE sense lead setting.
4. Solder the JP2 and JP3 jumpers to DISABLE the sense lead setting.
5. Close the back panel of the meter case by fastening the panel face at each corner with the four (4) screws.

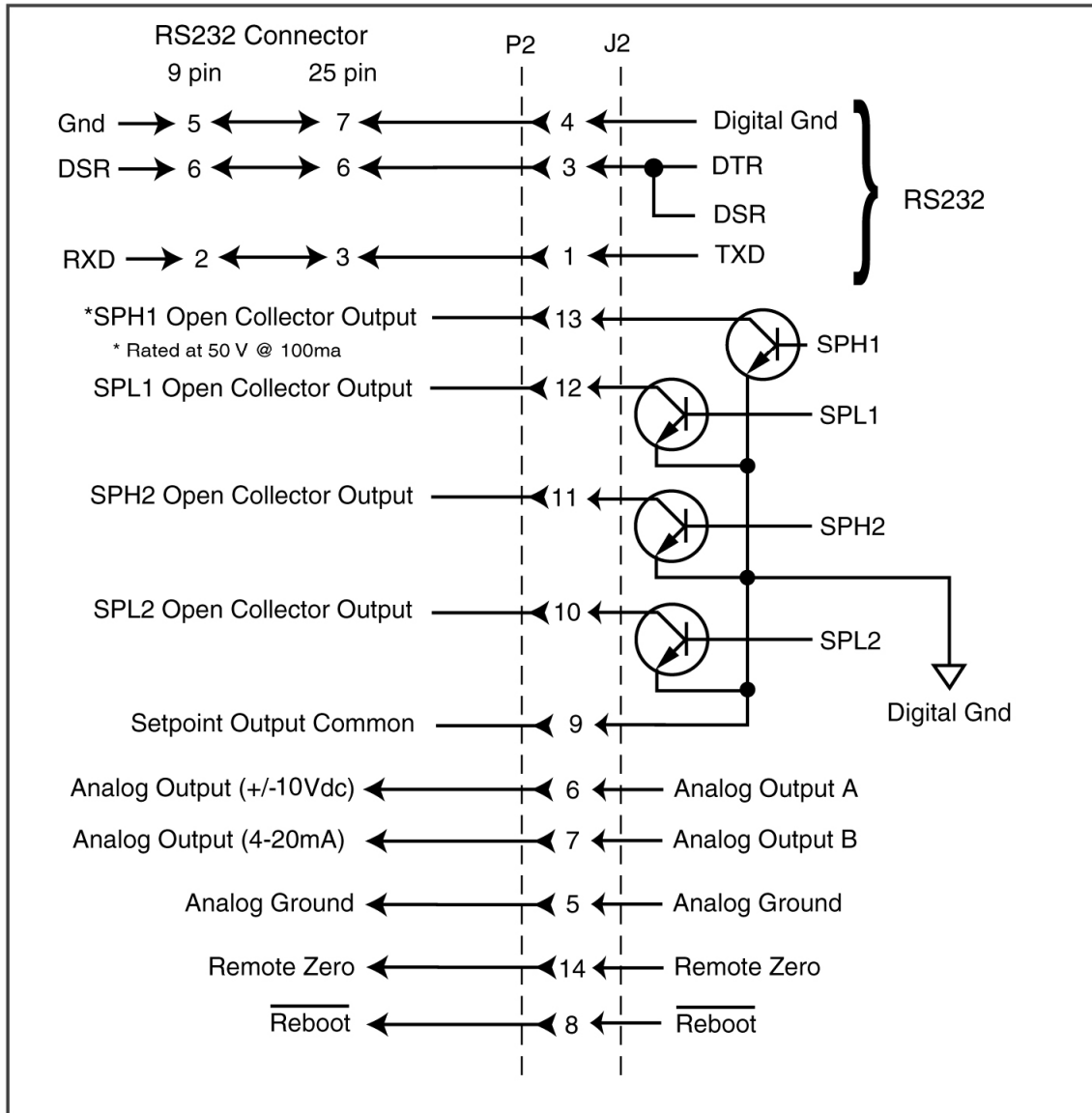

Figure 5 - Input/Output (I/O) Wiring

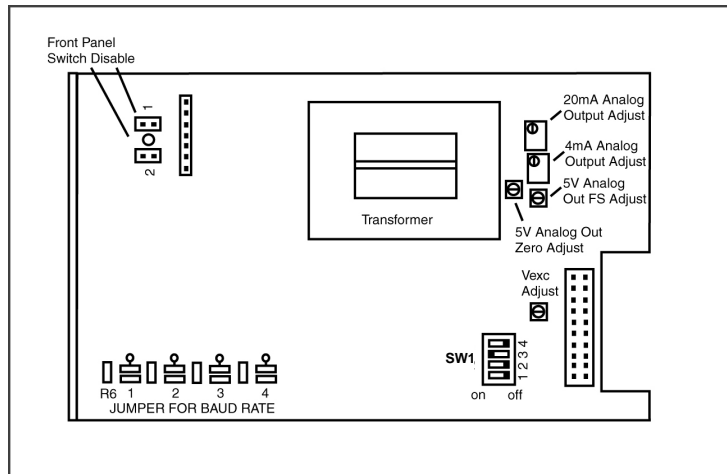

Figure 6 - Location of Jumpers and Potentiometers (Top View)



**Warning:** Remove AC power to the 8159 meter before removing any enclosure panels or making any internal adjustments or changes.

	Switch 1	Switch 2	Switch 3	Switch 4	Switch 5
<b>Bridge Excitation</b>					
5.0 V <sub>EXC</sub>	ON				
10.0 V <sub>EXC</sub>	OFF				
<b>Full-Scale Input</b>					
1.5 mV/V		ON	ON	OFF	
2.5 mV/V		OFF	ON	OFF	
3.5 mV/V		ON	OFF	OFF	
4.5 mV/V		OFF	OFF	ON	

Figure 7 - SW1 Switch Settings

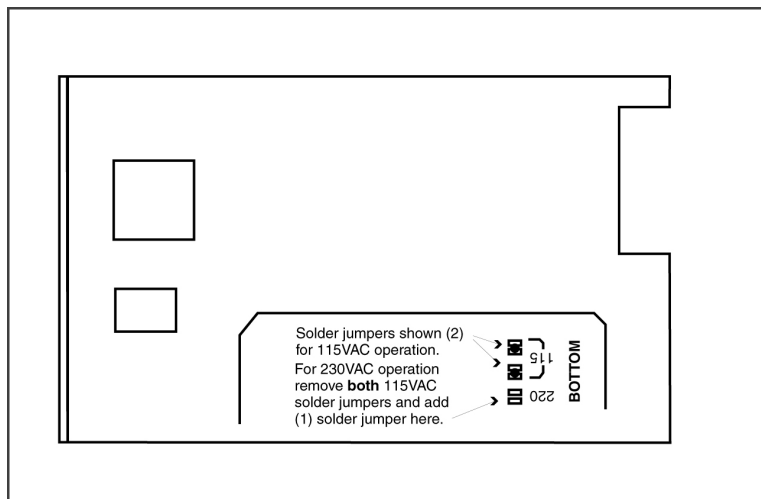

Figure 8 - Location of Jumper (Bottom View)



**Warning:** Remove AC power to the 8159 meter before removing any enclosure panels or making any internal adjustments or changes.

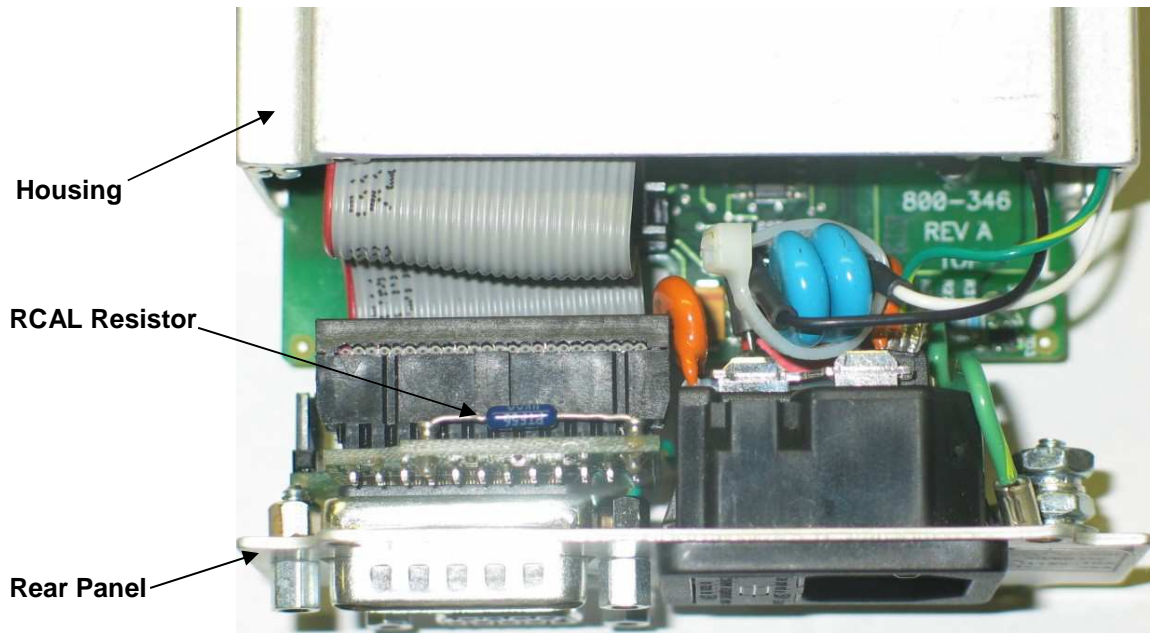

Figure 9 - Location of RCAL Resistor (Top View)



**Warning:** Remove AC power to the 8159 meter before removing any enclosure panels or making any internal adjustments or changes.

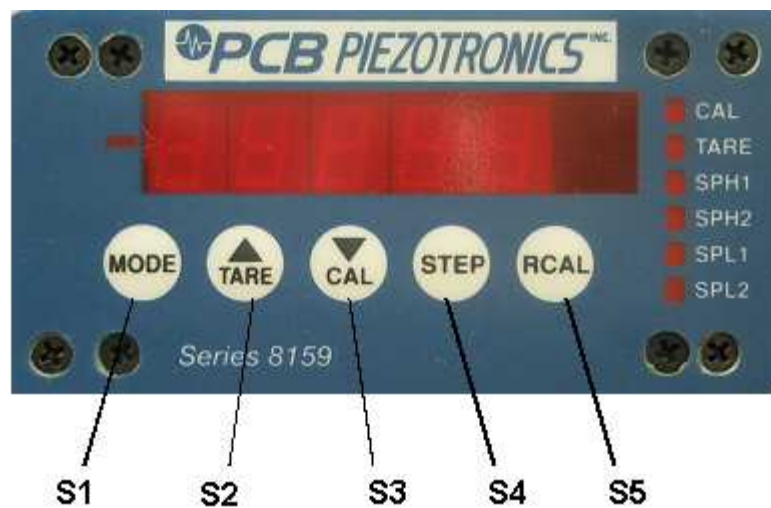

Figure 10 - Front Panel Switches

## 4.0 SWITCH DEFINITIONS

### Mode Selection Switch (S1)

S1 is used to cycle through the various set points, Hysteresis, and calibration values and decimal point locations. The sequence is as follows. The designators, in parenthesis, identify text that will be displayed, momentarily, followed by the value.

Set Point High 1 (SPH1)  
Set Point Low 1 (SPL1)  
Set Point High 2 (SPH2)  
Set Point Low 2 (SPL2)  
Hysteresis High (HH)  
Hysteresis Low (HL)  
Auto Cal (CAL)  
Decimal Point (dP)  
Exit

While in the Mode Selection sequence, the indicator is no longer monitoring the input signal. To exit, depress S1, once, after the Decimal Point selection is completed.

### Increment Switch (S2)

This switch serves two functions, depending on the present status of S1. If the instrument is in the Mode Selection sequence, this switch increments the flashing digit.

If the instrument is in its normal operating mode, S2 becomes the TARE switch. If the TARE LED, located on the front panel, is not illuminated, depressing S2 once will automatically zero the readout and illuminate the TARE LED. Depressing S2 again will UNTARE the readout and extinguish the TARE LED. TARING is accomplished by storing the reading prior to TARING and subtracting this value from all subsequent readings. It does not alter the calibration of the instrument. A remote tare function is available. See Section 6.0.

### Decrement Switch (S3)

This switch serves two functions, depending on the present status of S1. If the instrument is in the Mode Selection sequence, this switch will decrement the flashing digit.

If the instrument is in its operating mode, S3 becomes an AUTO CAL switch.

**CAUTION:** *Depressing this switch will cause the instrument to recalibrate its full-scale reading. Be sure to read the CALIBRATION INSTRUCTIONS before using this switch.*

### Step Switch (S4)

This switch also serves two functions, depending on the present status of S1. If the instrument is in the Mode Selection sequence, this switch allows the user to cycle through the digits. Used in conjunction with S2 and S3, it allows rapid updating of the Set Point, Hysteresis and Cal values.

### RCAL Switch (S5)

This switch activates a reed relay that places a precision calibration resistor across Sig(-) and Vexc(-) for a positive RCAL reading, or across Sig(+) and Vexc(-) for a negative RCAL reading.

The calibration resistor is pre-installed at the factory when the conditioner is purchased with a sensor as part of a system. The resistor is mounted on terminals located inside the back panel of the conditioner. Removing the back panel can access it. See Figure 9.

### Front Panel Switch Disable Jumper (Reference Figure 6)

This jumper, when removed, disables S1, S2, S3 and S4.

## 5.0 FUNCTION DEFINITIONS

### Set Point High 1 (SPH1)

SPH1 is the present value being constantly compared with the displayed reading. If the magnitude and sign of the reading exceeds the present SPH1 value, the SPH1 relay will activate (relay option assembly required) and the front panel LED (H1) will illuminate. If the displayed reading equals the SPH1 value, nothing will happen. If SPH1 is exceeded, the readout must then drop below SPH1 less the Hysteresis High (HH) value before the relay deactivates and the H1 LED turns off.

### Set Point Low 1 (SPL1)

SPL1 is another preset value being constantly compared with the displayed reading. If the magnitude and sign of the displayed reading is less than the SPL1 present value, the SPL1 relay will activate (relay option assembly required) and the front panel LED (L1) will illuminate. If the displayed reading equals the SPL1 value, nothing will happen. If the displayed reading drops below SPL1, it must then exceed SPL1 plus the Hysteresis Low (HL) value before the relay deactivates and the L1 LED turns off.

### Set Point High 2 (SPH2)

SPH2 is independent and functions identically to SPH1. SPH2 has its own relay contact outputs and front panel LED (H2).

### Set Point Low 2 (SPL2)

SPL2 is independent and functions identically to SPL1. SPL2 has its own relay contact outputs and front panel LED (L2).

### Hysteresis High (HH)

HH is the hysteresis value for SPH1 and SPH2. The hysteresis value determines the number of counts the displayed reading must fall below SPH1 and SPH2 values before deactivating their respective relays and LEDs. The maximum value of hysteresis is 99 counts while the minimum is 00 counts.

### Hysteresis Low (HL)

HL is the hysteresis value for SPL1 and SPL2. The hysteresis value determines the number of counts the displayed reading must exceed SPL1 and SPL2 values before deactivating their respective relays and LEDs. The maximum value of hysteresis is 99 counts while the minimum is 00 counts.

### Auto Cal (CAL)

This input allows the user to calibrate the full-scale readout to any desired engineering points. The CAL number is entered in the same way as the Set Point and Hysteresis values. This input must be entered prior to performing the calibration. The CAL number may be any number from 1 to 99,999. Zero is an invalid CAL number. For best stability and performance. Keep the maximum CAL number below 19,999 counts.

### Decimal Point (dP)

dP allows selection of decimal point locations for display. The locations selectable are X.XXXX, XX.XXX, XXX.XX, XXXX.X, XXXXX.

### Min./Max. Recall (HI/LO)

The HI and LO values are the maximum and minimum values, respectively, of the displayed readings. Sign and magnitude are constantly compared with the displayed readings at the instrument update rate. The maximum value is initialized to -99,999 and the minimum value to 99,999.

## **6.0 OPERATING INSTRUCTIONS**

### TURN-ON INSTRUCTIONS

Reference Figures 4 and 5 for proper input and output signal wiring.

1. Apply power to the instrument.
2. Verify the instrument readout blanks momentarily, then displays the value of the input signal.
3. Allow 30-minute warm-up with transducer connected.

### PROGRAM INSTRUCTIONS

Four front panel switches (S1, S2, S3, S4) allow the user to program Set Point, Hysteresis, Calibration Number (CAL) and Decimal Points and monitor minimum, maximum or real time values.

1. Depress MODE (S1) switch once. The text SPH1 followed by the current value of Set Point High 1 (SPH1) will be displayed. The system will idle in this condition until S2, S3, or S4 is depressed. If S2 or S3 is depressed, the most significant digit will be incremented or decremented, respectively. Incrementing the most significant digit will display numbers from -9 to 9.

Depressing S4 will cause selection of the next least significant digit position for updating. The digit being updated will be flashing. Using S2, S3, and S4, set Set Point High 1 to the desired value.

2. Depress MODE (S1) switch once. The text SPL1 followed by the current value of Set Point Low 1 will be displayed. Repeat Step 1 to set Set Point Low 1 to the desired value.
3. Depress MODE (S1) switch once. The text SPH2 followed by the current value of Set Point High 2 will be displayed. Repeat Step 1 to set Set Point High 2 to the desired value.
4. Depress MODE (S1) switch once. The text SPL2 followed by the current value of Set Point Low 2 will be displayed. Repeat Step 1 to set Set Point Low 2 to the desired value.
5. Depress MODE (S1) switch once. The text HH followed by the current value of Hysteresis High will be displayed. Repeat Step 1 to set Hysteresis High to the desired value. The maximum value for HH is 99 counts.
6. Depress MODE (S1) switch once. The text HL followed by the current value of Hysteresis Low will be displayed. Repeat Step 1 to set Hysteresis Low to the desired value. The maximum value for HL is 99 counts.
7. Depress MODE (S1) switch once. The text CAL followed by the current CAL number will be displayed. Repeat Step 1 to set the CAL number. The maximum CAL number is 99,999.
8. Depress MODE (S1) switch once. The text dP followed by the current decimal position will be shown flashing. Increment (S2) or decrement (S3) the decimal point to the desired location.
9. Depress MODE (S1) switch once. The instrument will exit the Mode Selection Sequence and enter the normal operating mode (i.e. monitoring the input signal).

This is the end of the PROGRAM INSTRUCTIONS.

### REMOTE TARE (ZERO)

Remote zero will tare out any residual value, such as that caused by fixturing a load cell into a test stand. It is activated by momentarily connecting pin 14 to pin 5 on the 15-pin I/O connector J8.

### REMOTE REBOOT

This feature is used to clear the high or low set points if required. It is activated by momentarily connecting pin 8 to pin 5 on the 15-pin I/O connector J2.

## 7.0 CALIBRATION INSTRUCTIONS

The Series 8159 can be calibrated using (2) different methods. The first method uses actual or simulated ZERO and FULL SCALE (FS) inputs. Actual inputs may come from a strain gage transducer loaded with calibrated weights. Simulated inputs may come from a strain gage bridge simulator. The second method utilizes an RCAL resistor to simulate a load on a strain gage bridge. The RCAL resistor is activated when the RCAL (S5) switch is depressed. Reference Figure 10 for location of S5.

### ACTUAL LOAD OR BRIDGE SIMULATED METHOD

1. Connect the strain gage transducer to the instrument using Figure 4 as a reference. Do not apply any load to the transducer.
2. Apply power to the instrument.

**NOTE:** If the instrument was previously calibrated and no new calibration is required, do not proceed any further. All previous calibration information is stored in non-volatile EEPROM and is ready for use when power to the instrument is reapplied.

3. Calculate the CAL NUMBER by verifying the load that will be used to calibrate the full scale of the Series 8159.

Example: If a 500-pound load is used to calibrate full scale and the desired readout is 500.0, the CAL NUMBER will be 5000. The decimal point can be selected later. If the desired readout is 500 then the CAL NUMBER will be 500.

4. Program in the CAL NUMBER. Reference PROGRAM INSTRUCTIONS, Step 7. If the CAL NUMBER was previously programmed, skip this step.
5. The TARE and CAL LED's on the front panel should be illuminated.
6. Depress the INCREMENT (S2) switch and hold until the TARE LED extinguishes. The instrument should now display the UNTARED reading.
7. Depress the DECREMENT (S3) switch and hold until the CAL LED extinguishes. The instrument should now display the UNCALIBRATED reading.

8. With no load on the transducer, verify the instrument reading is low.
9. Depress the INCREMENT (S2) switch and hold until the TARE LED illuminates. The readout should be ZERO +/- 1 digit.
10. Apply the FULL SCALE load to the transducer. If a strain gage simulator is used, set it to the desired mV/V setting. The instrument should display a value greater than 01000. For optimum performance the readout should be closer to 19000. Ignore decimal point.
11. Depress the DECREMENT (S3) switch and hold until the CAL LED illuminates. The readout should display the CAL NUMBER +/- 1 digit.

The CALIBRATION sequence is now complete.

**NOTE:** Calibration information (tare and slope values) is maintained in non-volatile memory and is updated every time CALIBRATION Steps 9 and 11 are performed. TARING the display does not change the scale factor (slope value) calculated when Step 11 is completed.

RCAL (SIMULATED) LOAD METHOD

1. Connect the strain gage transducer to the instrument using Figure 4 as a reference. Do not apply any load to the transducer.
2. An RCAL resistor is provided and installed on the rear panel printed circuit board.
3. Apply power to the instrument.

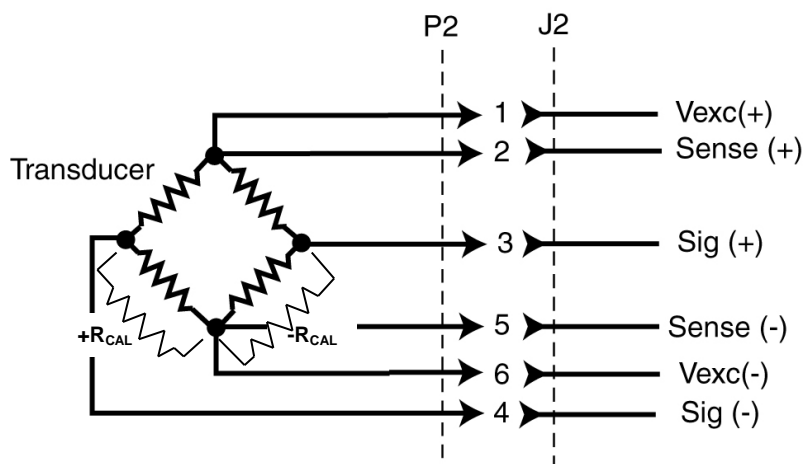

Figure 11 - Transducer Connections

**NOTE:** If the instrument was previously calibrated and no new calibration is required, do not proceed any further. All previous calibration information is stored in non-volatile EEPROM and is ready for use when power to the instrument is reapplied.

4. Set the CAL NUMBER to the full-scale value provided with the RCAL resistor. This is the shunt calibration valve indicated on the sensor's calibration certificate.

Example: If the RCAL resistor supplied with the instrument creates an output equivalent to 80% of a full-scale 500-pound load, set the CAL NUMBER to 400.00, 0400.0 or 00400.

See Section 6.0, Program Instructions, for details on how to set this value.

5. The TARE and CAL LED's on the front panel should be illuminated.
6. Depress the INCREMENT (S2) switch and hold until the TARE LED extinguishes. The instrument should now display the UNTARED reading.
7. Depress the DECREMENT (S3) switch and hold until the CAL LED extinguishes. The instrument should now display the UNCALIBRATED reading.
8. With no load on the transducer, verify the readout is approximately zero.
9. Depress the INCREMENT (S2) switch and hold until the TARE LED illuminates. The readout should be ZERO +/- 1 digit.
10. Depress and hold the RCAL switch. The display should read a value greater than 01000. For optimum performance the readout should be closer to 19000. Ignore decimal point. If system calibration was done by PCB, this displayed valve will be equal to the shunt calibration valve shown on the system calibration certificate.
11. While holding down the RCAL switch, depress the DECREMENT (S3) switch and hold until the CAL LED illuminates. The readout should display the CAL NUMBER +/- 1 digit.

The RCAL CALIBRATION sequence is now complete.

**NOTE:** Calibration information (tare and slope values) is maintained in non-volatile memory and is updated every time CALIBRATION Steps 9 and 10 are performed. TARING the display does not change the scale factor (slope value) calculated when Step 10 is completed.

**8.0 OPTIONS**

RS232 SERIAL COMMUNICATION OUTPUT

The RS232 transmission is of the displayed reading and is transmitted once every display update, if the DSR line is TRUE (HIGH). The data format is described below.

- 1. No parity bit
- 2. 1 stop bit
- 3. 8 data bits

The data transmission sequence is described below.

- 1. Sign: plus or minus (1st word)
- 2. Magnitude: most significant digit (MSD) first (2nd thru 6th word)
- 3. Decimal point: exponent (7th word)
- 4. End of Line (EOL): Control Z (8th word)

Note: Data are transmitted in ASCII characters. The decimal position is transmitted as a power of 10 exponent in ASCII.

The decimal point as a power of 10 exponent is:

- x.xxxx 4 (ASCII)
- xx.xxx 3 (ASCII)
- xxx.xx 2 (ASCII)
- xxxx.x 1 (ASCII)
- xxxxx 0 (ASCII)

The baud rate is set by solder jumpers (Reference Figure 6 for location). The following baud rate with their corresponding solder jumpers are shown below.

Solder Jumper	Baud Rate
1 2 3 4	Rate
0 1 1 1	600
1 0 0 0	1200
1 0 1 0	2400
1 1 0 0	4800
1 1 0 1	7200
1 1 1 0	9600 (default)
1 1 1 1	19200

"0" = solder jumper ON

"1" = solder jumper removed

SERIES 8159 PROGRAM MENU DIAGRAM

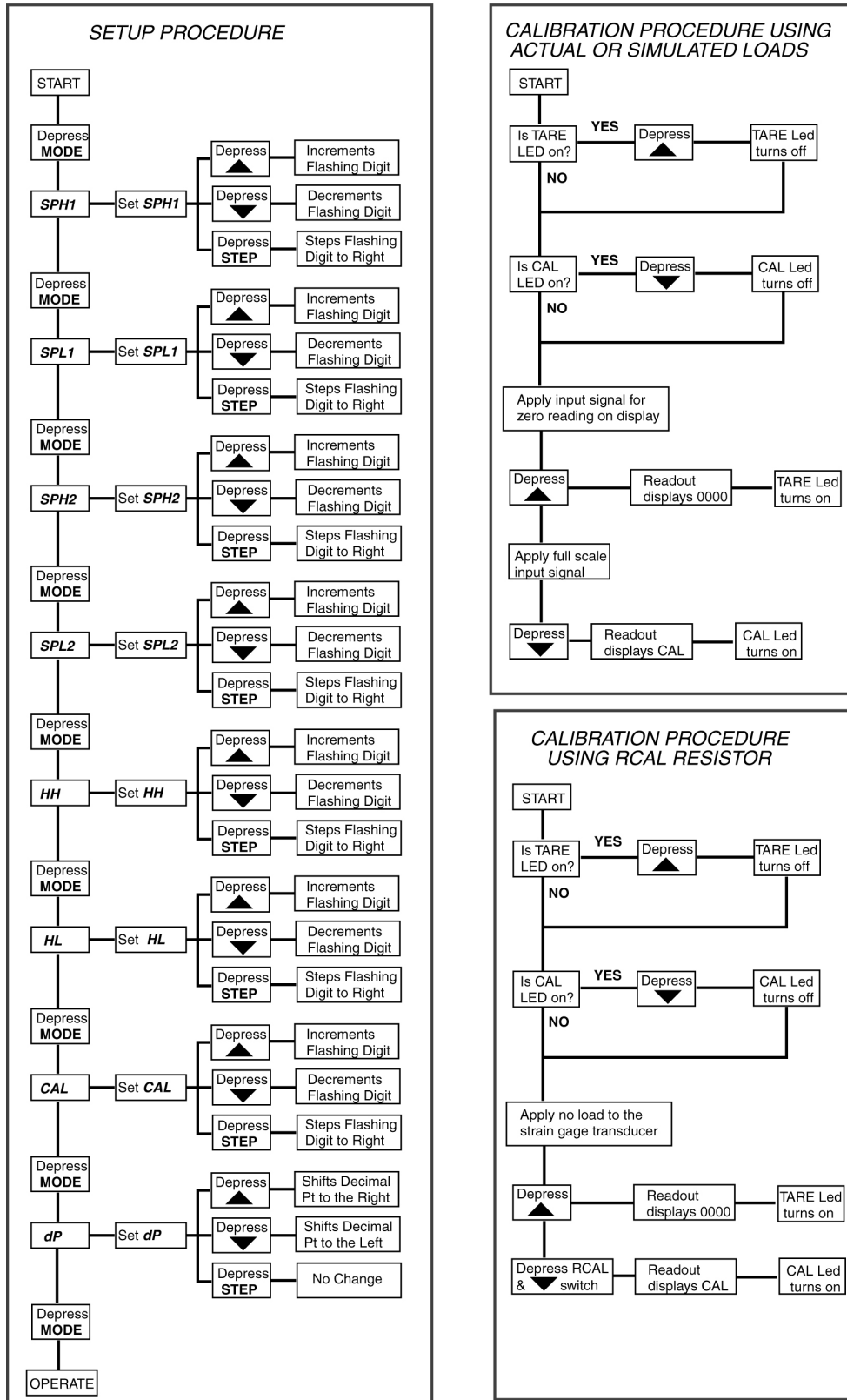

Figure 12

	ENGLISH	SI	
<b>Performance</b>			
Linearity	± 0.015 % FS	± 0.015 % FS	
<b>Environmental</b>			
Temperature Range	+14 to +122 °F	-10 to +50 °C	
Temperature Stability	± 0.56 µV/°F	± 1 µV/°C	
Maximum Humidity	90 %	90 %	[5]
<b>Electrical</b>			
Excitation Voltage(± 0.5 %)	10 VDC	10 VDC	[1]
Full Scale Input	2.5 mV/V	2.5 mV/V	[2]
Output Voltage(Analog Signal)	± 10 VDC	± 10 VDC	
Output Current(Analog Signal)	4 to 20 mA	4 to 20 mA	
Output Bandwidth	0 to 1000 Hz	0 to 1000 Hz	[3]
Digital Resolution	1 part in 19,999	1 part in 19,999	
Common Mode Rejection	>120 @50-60 Hz	>120 @50-60 Hz	
Display Type	0.4in. (10.2mm) LED	0.4in. (10.2mm) LED	
Display Range	± 99,999 (5 digits)	± 99,999 (5 digits)	
Decimal Point	Adjustable via front panel	Adjustable via front panel	
Set Points, Open Collector	2 High and 2 Low	2 High and 2 Low	
Shunt Calibration	Actuated via front panel	Actuated via front panel	
Shunt Calibration Resistor	Accessible through rear panel	Accessible through rear panel	[4]
Power Required	115/50 to 60 VAC/Hz	115/50 to 60 VAC/Hz	
Input	Fully Differential (bi-polar)	Fully Differential (bi-polar)	
<b>Physical</b>			
Electrical Connector(Sensor)	9-Pin Female D-sub	9-Pin Female D-sub	
Electrical Connector(input/output)	15-Pin Male D-sub	15-Pin Male D-sub	
Electrical Connector(AC Power Input)	IEC 320	IEC 320	
Size (Height x Width x Diameter)	1.89 in x 3.78 in x 5.88 in	48 mm x 96 mm x 149 mm	[6]
Weight	1.3 lb	0.59 kg	

**OPTIONAL VERSIONS**

Optional versions have identical specifications and accessories as listed for the standard model except where noted below. More than one option may be used.

**F** - 230 VAC operation

**NOTES:**

[1] Default Value: Internally selectable between 5 VDC and 10 VDC @120 mA max with remote sense short circuit current limiting.

[2] Default Value: Internally selectable between 1.5 mV/V, 2.5 mV/V, and 3.5 mV/V.

[3] Upper frequency limited by single pole, low-pass filter.

[4] Unit set to 230 VAC when ordered as "F8159-0012A", internally selectable

[5] At +104 °F (+40 °C)

[6] 1/8 DIN size.

[7] See PCB Declaration of Conformance PS113 for details.

**SUPPLIED ACCESSORIES:**  
Model 017 AC Line Cord

Entered: AP	Engineer: PE	Sales: KWW	Approved: DA	Spec Number:
Date: 5/21/2013	Date: 5/21/2013	Date: 5/21/2013	Date: 5/21/2013	<b>24520</b>

**PCB Load & Torque, Inc.**  
 24350 Indoplex Circle  
 Farmington Hills, MI 48335  
 UNITED STATES  
 Phone: 866-684-7107  
 Fax: 716-684-0987  
 E-Mail: [Itinfo@pcbloadtorque.com](mailto:Itinfo@pcbloadtorque.com)  
 Web site: <http://www.pcbloadtorque.com>



[7] All specifications are at room temperature unless otherwise specified.  
 In the interest of constant product improvement, we reserve the right to change specifications without notice.  
 ICP® is a registered trademark of PCB Group, Inc.

27735

PCB Load & Torque Inc. claims proprietary rights in the information disclosed hereon. Neither it nor any reproduction thereof will be disclosed to others without the written consent of PCB Load and Torque Inc.

REVISIONS		
REV	DESCRIPTION	ECO
A	WAS +/-5VDC, UPDATED TO L&T - 05.14.13, PTE	41416

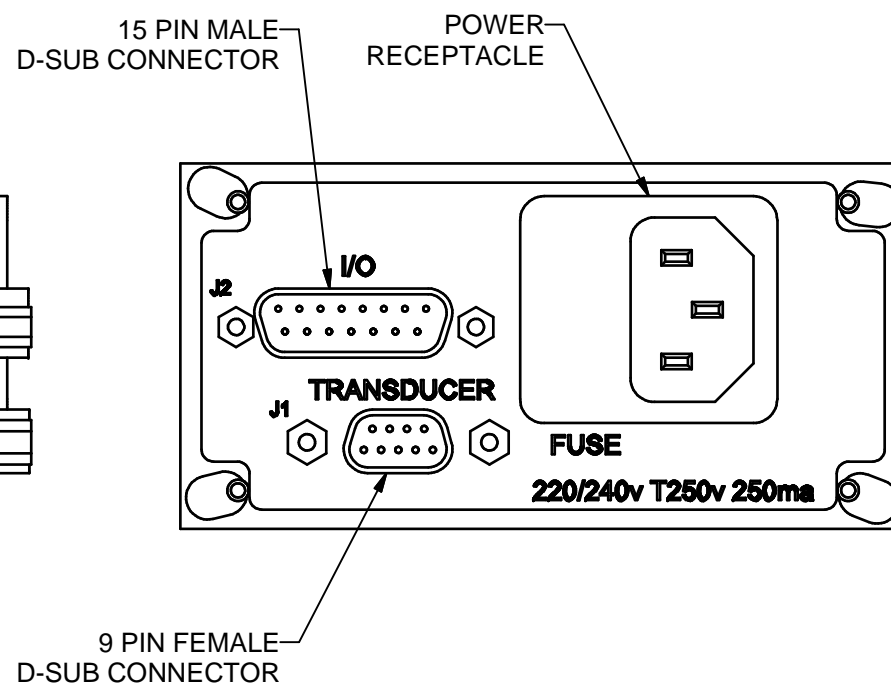
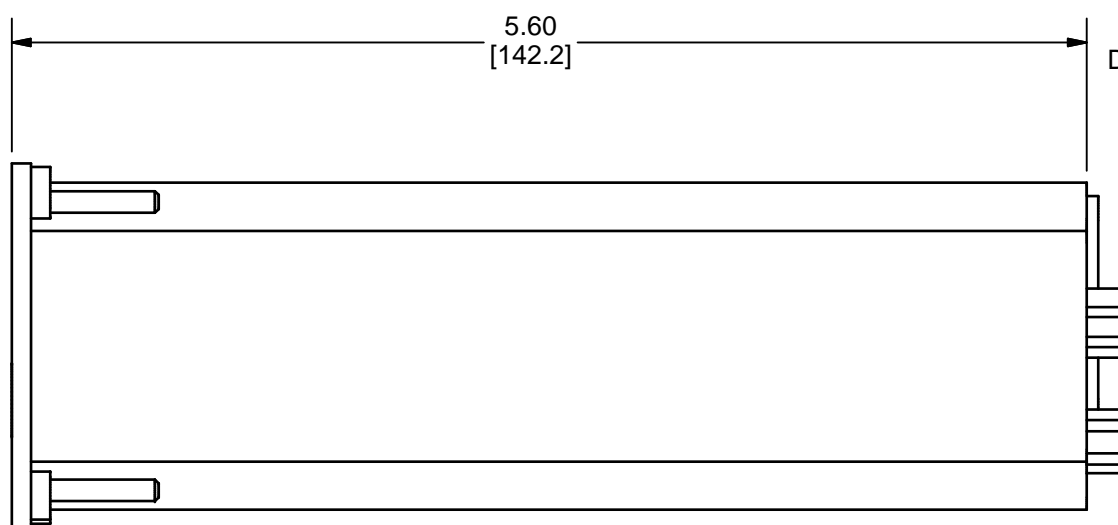
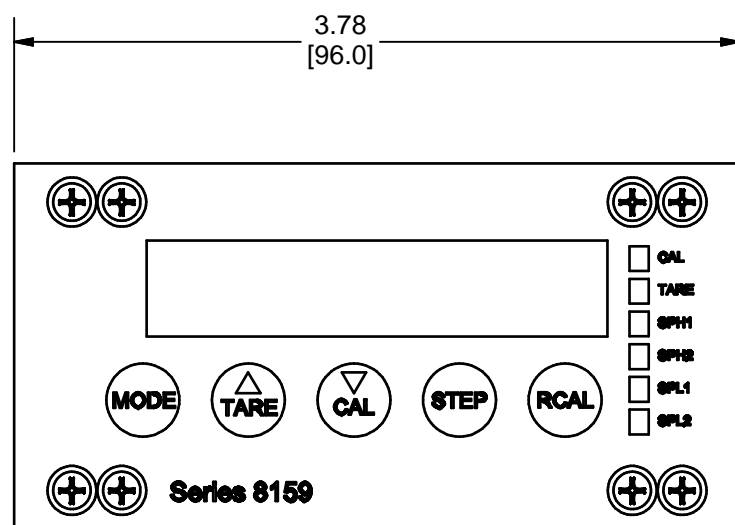
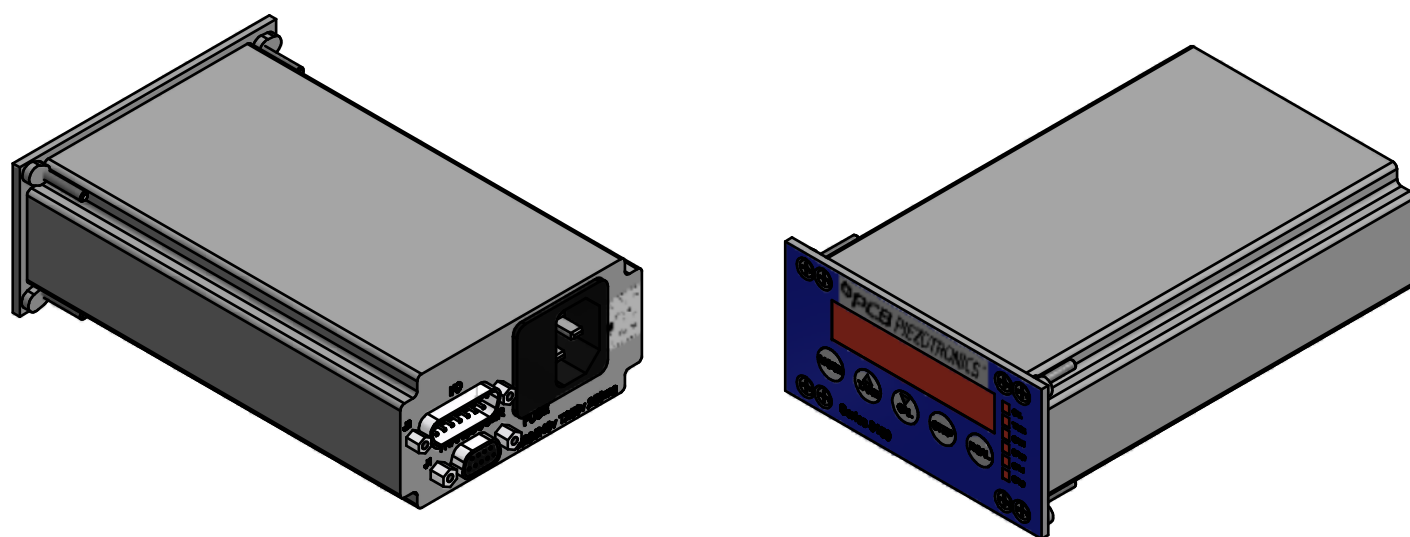

15 PIN D-SUB CONNECTOR PIN OUT	
PIN	CONNECTION
1	RXD
2	N/C
3	DSR
4	GROUND
5	ANALOG GROUND
6	ANALOG OUTPUT (+/- 10Vdc)
7	ANALOG OUTPUT (4-20 m A)
8	REBOOT
9	SETPOINT OUTPUT COMMON
10	SPL2 OPEN COLLECTOR OUTPUT
11	SPH2 OPEN COLLECTOR OUTPUT
12	SPL1 OPEN COLLECTOR OUTPUT
13	SPH1 OPEN COLLECTOR OUTPUT
14	REMOTE ZERO
15	N/C

9 PIN D-SUB PIN OUT	
PIN	CONNECTION
1	VEXC (+)
2	SENSE (+)
3	SIG (+)
4	SIG (-)
5	SENSE (-)
6	VEXC (-)
7	N/C
8	N/C
9	GROUND

UNLESS OTHERWISE SPECIFIED TOLERANCES ARE:		DRAWN	CHECKED	ENGINEER	 24350 Indoplex Circle, Farmington Hills, MI 48335 (716) 684-0001 E-MAIL: linfo@pcbloadtorque.com DWG. NO. <b>27735</b> SCALE: FULL SHEET 1 OF 1
DIMENSIONS IN INCHES	DIMENSIONS IN MILLIMETERS [ IN BRACKETS ]	JRM 09.17.04	DM 09.20.04	DMB 09.20.06	
DECIMALS XX ±.01 XXX ±.005	DECIMALS X ±.3 XX ±.13	TITLE			
ANGLES ± .5 DEGREES	ANGLES ± .5 DEGREES	OUTLINE DRAWING MODEL 8159A SIGNAL CONDITIONER			
FILLETS AND RADII .015 MAX	FILLETS AND RADII 0.38 MAX				