



**Model EX640B72**

**Industrial vibration sensor, 4 to 20mA output, 0 to 2.0 in/sec peak, 3 to 1**

**Installation and Operating Manual**

**For assistance with the operation of this product,  
contact PCB Piezotronics, Inc.**

**Toll-free: 800-959-4464  
24-hour SensorLine: 716-684-0001  
Fax: 716-684-3823  
E-mail: [imi@pcb.com](mailto:imi@pcb.com)  
Web: [www.imi-sensors.com](http://www.imi-sensors.com)**



**The information contained in this document supersedes all similar information that may be found elsewhere in this manual.**

**Total Customer Satisfaction** – PCB Piezotronics guarantees Total Customer Satisfaction. If, at any time, for any reason, you are not completely satisfied with any PCB product, PCB will repair, replace, or exchange it at no charge. You may also choose to have your purchase price refunded in lieu of the repair, replacement, or exchange of the product.

**Service** – Due to the sophisticated nature of the sensors and associated instrumentation provided by PCB Piezotronics, user servicing or repair is not recommended and, if attempted, may void the factory warranty. Routine maintenance, such as the cleaning of electrical connectors, housings, and mounting surfaces with solutions and techniques that will not harm the physical material of construction, is acceptable. Caution should be observed to insure that liquids are not permitted to migrate into devices that are not hermetically sealed. Such devices should only be wiped with a dampened cloth and never submerged or have liquids poured upon them.

**Repair** – In the event that equipment becomes damaged or ceases to operate, arrangements should be made to return the equipment to PCB Piezotronics for repair. User servicing or repair is not recommended and, if attempted, may void the factory warranty.

**Calibration** – Routine calibration of sensors and associated instrumentation is

recommended as this helps build confidence in measurement accuracy and acquired data. Equipment calibration cycles are typically established by the users own quality regimen. When in doubt about a calibration cycle, a good “rule of thumb” is to recalibrate on an annual basis. It is also good practice to recalibrate after exposure to any severe temperature extreme, shock, load, or other environmental influence, or prior to any critical test.

PCB Piezotronics maintains an ISO-9001 certified metrology laboratory and offers calibration services, which are accredited by A2LA to ISO/IEC 17025, with full traceability to N.I.S.T. In addition to the normally supplied calibration, special testing is also available, such as: sensitivity at elevated or cryogenic temperatures, phase response, extended high or low frequency response, extended range, leak testing, hydrostatic pressure testing, and others. For information on standard recalibration services or special testing, contact your local PCB Piezotronics distributor, sales representative, or factory customer service representative.

**Returning Equipment** – *Following these procedures will insure that your returned materials are handled in the most expedient manner.* Before returning any equipment to PCB Piezotronics, contact your local distributor, sales representative, or factory customer service representative to obtain a Return

Materials Authorization (RMA) Number. This RMA number should be clearly marked on the outside of all package(s) and on the packing list(s) accompanying the shipment. A detailed account of the nature of the problem(s) being experienced with the equipment should also be included inside the package(s) containing any returned materials.

A Purchase Order, included with the returned materials, will expedite the turn-around of serviced equipment. It is recommended to include authorization on the Purchase Order for PCB to proceed with any repairs, as long as they do not exceed 50% of the replacement cost of the returned item(s). PCB will provide a price quotation or replacement recommendation for any item whose repair costs would exceed 50% of replacement cost, or any item that is not economically feasible to repair. For routine calibration services, the Purchase Order should include authorization to proceed and return at current pricing, which can be obtained from a factory customer service representative.

**Warranty** – All equipment and repair services provided by PCB Piezotronics, Inc. are covered by a limited warranty against defective material and workmanship for a period of one year from date of original purchase. Contact

PCB for a complete statement of our warranty. Expendable items, such as batteries and mounting hardware, are not covered by warranty. Mechanical damage to equipment due to improper use is not covered by warranty. Electronic circuitry failure caused by the introduction of unregulated or improper excitation power or electrostatic discharge is not covered by warranty.

**Contact Information** – International customers should direct all inquiries to their local distributor or sales office. A complete list of distributors and offices can be found at [www.pcb.com](http://www.pcb.com). Customers within the United States may contact their local sales representative or a factory customer service representative. A complete list of sales representatives can be found at [www.pcb.com](http://www.pcb.com). Toll-free telephone numbers for a factory customer service representative, in the division responsible for this product, can be found on the title page at the front of this manual. Our ship to address and general contact numbers are:

PCB Piezotronics, Inc.  
3425 Walden Ave.  
Depew, NY 14043 USA  
Toll-free: (800) 828-8840  
24-hour SensorLine<sup>SM</sup>: (716) 684-0001  
Website: [www.pcb.com](http://www.pcb.com)  
E-mail: [info@pcb.com](mailto:info@pcb.com)

***Model 640/641/645/646 B7 Series Industrial 4-20mA Sensor***

---

CE



SENSORS AND INSTRUMENTATION FOR MACHINE CONDITION MONITORING

***Operating Guide with Enclosed Warranty Information***

---

***3425 Walden Avenue, Depew, New York 14043-2495***

***Phone (716) 684-0003***

***Fax (716) 684-3823***

***Toll Free Line 1-800-959-4IMI***

MANUAL NUMBER: 28077  
MANUAL REVISION: A  
ECN NUMBER: 25747

## **Table of Contents**

---

Introduction .....	Page 3
General Features	
Dimension Drawing .....	Page 4
Operation and Wiring .....	Page 5
Standard Wiring	
Taking Measurements	
RV Option	
TO Option	
EP Option	
ESD Sensitivity.....	Page 10

## **Warranty/Service**

---

Warranty, Service & Return Procedure .....	Page 11
Customer Service.....	Page 12

## Introduction

The Model 640/641/645/646 B7 Series Industrial 4-20mA Sensors combine the capabilities of a piezoelectric vibration sensor and a 4-20mA vibration transmitter. The sensor outputs a 4-20mA signal that is proportional to the overall velocity or acceleration of the machinery. Ideal for monitoring the vibration of process equipment such as fans, motors and pumps, the output of the sensor is used for process control or predictive maintenance. There are many options in this series. Please refer to specific specification sheets for further details.

### **General Features**

- Imbedded Piezoelectric Accelerometer for improved accuracy and frequency response.
- Vibration range can be in Acceleration or Velocity.
- Allows for continuous vibration monitoring of critical applications.
- Reduces sophisticated vibration analysis requirements.
- RV (Raw Vibration) option for conducting frequency analysis and machinery diagnostics.
- TO (Temperature Output) option via an independent 4-20mA loop.
- EP option includes an Explosion Proof capped elbow.
- Readily interfaces to existing process control and predictive maintenance equipment.
- Rugged stainless steel construction for applications in harsh environments.
- Flexible design allows for various custom requirements.

### Dimension Drawing

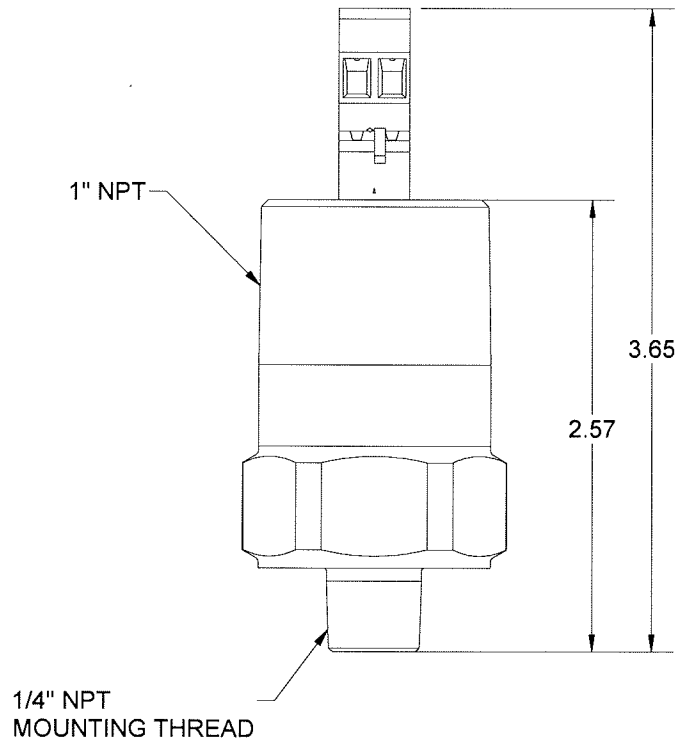
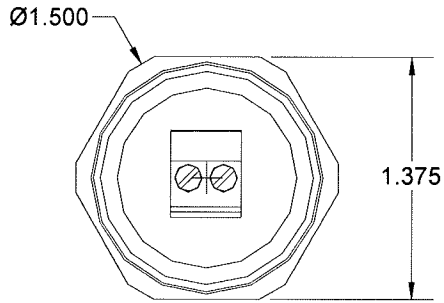

Inch (mm)

## Operation and Wiring

### Standard Wiring

The Model 640/641/645/646 B7 Series uses plug-in type screw terminal connectors for all input and output connections and operate from a standard 2-wire, 4-20mA loop. Attach the positive (+) input from the power supply to Pin 2 and the negative (-) input from the power supply to Pin 3.

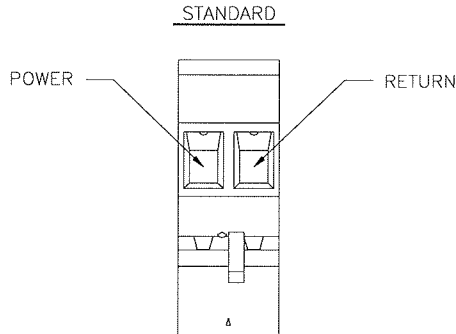

**Figure 1 – wiring: standard connection**

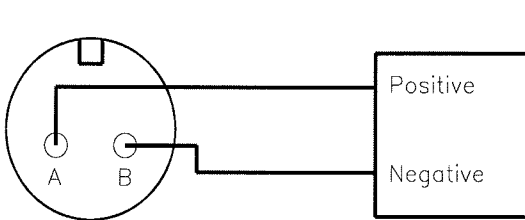

**Figure 2 – wiring: loop powered**

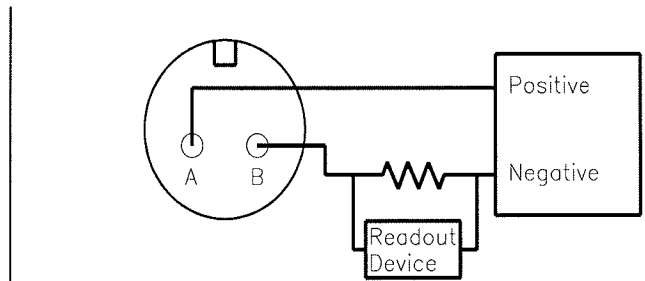

**Figure 3 – wiring: loop powered/DC source**

If using a standard DC power supply, install either an ammeter and/or load resistor in line with the return connection Pin 3.

The resistor will generate a DC voltage that is proportional to current by:

$$V = IR$$

$$\text{If } R = 500\Omega \text{ and } I = 6\text{mA, then } V = 3\text{Vdc}$$

**Note:**

- Resistor value must be less than:  $(V_{\text{supply}} - 12) \times 50$ .

### Taking Measurements

When measuring the current output from the unit, use the following formula to calculate the vibration level:

$$\text{Vibration Output} = (\text{Measured Output} - 4\text{mA}) \times (\text{Full Scale Vibration Output} / 16\text{mA})$$

<b>Measured mA</b>	<b>640BX0</b>	<b>640BX1</b>	<b>640BX2</b>
4.00	0.0 ips, pk	0.0 ips, pk	0.0 ips, pk
8.00	0.125 ips, pk	0.25 ips, pk	0.5 ips, pk
12.0	0.25 ips, pk	0.5 ips, pk	1.0 ips, pk
15.75	0.37 ips, pk	0.73 ips, pk	1.47 ips, pk
20	0.5 ips, pk	1.0 ips, pk	2.0 ips, pk

<b>Measured mA</b>	<b>641BX0</b>	<b>641BX1</b>	<b>641BX2</b>
4.00	0.0 ips, rms	0.0 ips, rms	0.0 ips, rms
8.00	0.125 ips, rms	0.25 ips, rms	0.5 ips, rms
12.0	0.25 ips, rms	0.5 ips, rms	1.0 ips, rms
15.75	0.37 ips, rms	0.73 ips, rms	1.47 ips, rms
20	0.5 ips, rms	1.0 ips, rms	2.0 ips, rms

<b>Measured mA</b>	<b>645</b>	<b>646</b>
4.00	0.0 g rms	0.0 g rms
8.00	1.25 g rms	2.50 g rms
12.0	2.50 g rms	5.00 g rms
15.75	3.67 g rms	7.34 g rms
20	5.00 g rms	10.0 g rms

**RV Option**

The RV (raw vibration) option includes a 100mV/g  $\pm 20\%$  additional output. The accelerometer frequency range is 1 Hz-1 kHz, maximum amplitude of 15 g-pk. Data collectors or analyzers can use this vibration signal for further analysis.

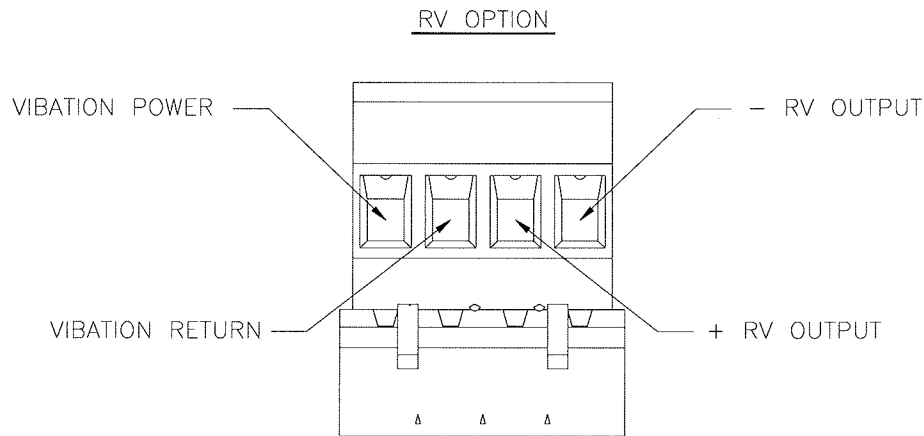

**Figure 3 – RV wiring**

**Note:**

- The Acceleration Signal Negative has to be isolated from any grounding. If this terminal is grounded, the 4-20mA loop will short, causing no output.
- The acceleration output signal is ideally suited for use with portable battery powered data collectors or analyzers.

**TO Option**

The TO (Temperature Output) option includes an additional independent 4-20mA output for temperature measurement. The temperature range is from -40°C to 125°C with an overall accuracy of  $\pm 5\%$ FSO. The imbedded temperature sensor monitors the environment internal to the sensor housing and is situated at approximately mid level.

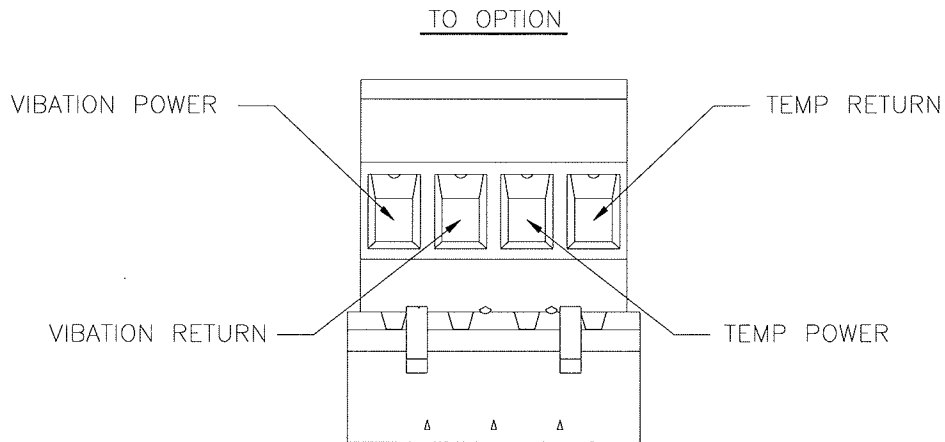

**Figure 4 – TO wiring**

**Note:**

- The same power supply can be used for both 4-20mA loops. Connect both positive terminals directly to the power supply, then use the negative terminals for independent process loops.

**EP Option**

The EP option includes an Explosion Proof capped elbow for applications in rigid or IMC conduit systems where space is limited and access is needed for pulling conductors or maintenance. Standard conduit hub size is 1"NPT.

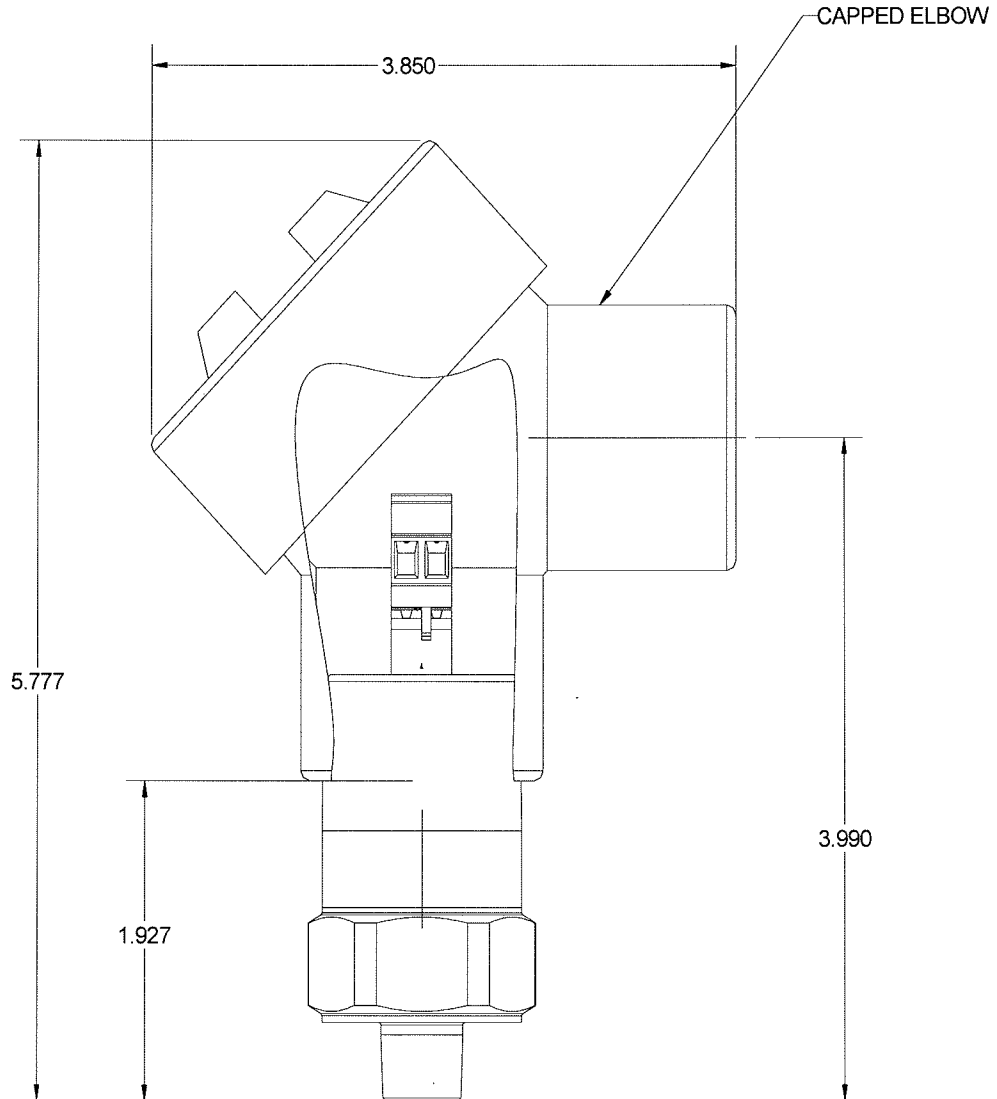

**Figure 5 – EP option**

## **Warning 1 – ESD sensitivity**

---

**The power supply/signal conditioner should not be opened by anyone other than qualified service personnel.** This product is intended for use by qualified personnel who recognize shock hazards and are familiar with the safety precautions required to avoid injury.

## **Warning 2 – ESD sensitivity**

---

This equipment is designed with user safety in mind; however, the protection provided by the equipment may be impaired if the equipment is used in a manner not specified by PCB Piezotronics, Inc.

## **Caution 1 – ESD sensitivity**

---

**Cables can kill your equipment.** High voltage electrostatic discharge (ESD) can damage electrical devices. Similar to a capacitor, a cable can hold a charge caused by triboelectric transfer, such as that which occurs in the following:

- *Laying on and moving across a rug,*
- *Any movement through air,*
- *The action of rolling out a cable, and/or*
- *Contact with a non-grounded person.*

**The PCB solution for product safety:**

- *Connect the cables only with the AC power off.*
- *Temporarily “short” the end of the cable before attaching it to any signal input or output.*

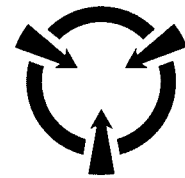

**CAUTION**  
ELECTROSTATIC  
DISCHARGE SENSITIVE

## **Caution 2 – ESD sensitivity**

---

**ESD considerations should be made prior to performing any internal adjustments on the equipment.** Any piece of electronic equipment is vulnerable to ESD when opened for adjustments. Internal adjustments should therefore be done ONLY at an ESD-safe work area. Many products have ESD protection, but the level of protection may be exceeded by extremely high voltage.

## **Warranty**

---

IMI instrumentation is warranted against defective material and workmanship for 1 year unless otherwise expressly specified. Damage to instruments caused by incorrect power or misapplication, is not covered by warranty. *If there are any questions regarding power, intended application, or general usage, please consult with your local sales contact or distributor.* Batteries and other expendable hardware items are not covered by warranty.

## **Service**

---

Because of the sophisticated nature of IMI instrumentation, field repair is typically **NOT** recommended and may void any warranty. If factory service is required, return the instrumentation according to the "Return Procedure" stated below. *A repair and/or replacement quotation will be provided prior to servicing at no charge.* Before returning the unit, please consult a factory IMI applications engineer concerning the situation as certain problems can often be corrected with simple on-site procedures.

## **Return procedure**

---

*To expedite returned instrumentation, contact a factory IMI applications engineer for a RETURN MATERIAL AUTHORIZATION (RMA) NUMBER. Please have information available such as model and serial number. Also, to insure efficient service, provide a written description of the symptoms and problems with the equipment to a local sales representative or distributor, or contact IMI if none are located in your area.*

Customers outside the U.S. should consult their local IMI distributor for information on returning equipment. For exceptions, please contact the International Sales department at IMI to request shipping instructions and an RMA. For assistance, please call (716) 684-0003, or fax us at (716) 684-3823. You may also receive assistance via e-mail at [imi@pcb.com](mailto:imi@pcb.com) or visit our web site at [www.pcb.com](http://www.pcb.com).



## Customer Service

---

IMI, a division of PCB Piezotronics, guarantees **Total Customer Satisfaction**. If, at any time, for any reason, you are not completely satisfied with any IMI product, IMI will repair, replace, or exchange it at no charge. You may also choose to have your purchase price refunded.

IMI offers to all customers, at no charge, 24-hour phone support. This service makes product or application support available to our customers, day or night, seven days a week. When unforeseen problems or emergency situations arise, call the **IMI Hot Line at (716) 684-0003**, and an application specialist will assist you.



3425 Walden Avenue, Depew, NY 14043-2495  
Phone: (716) 684-0003 • USA Fax: (716) 684-3823 • INTL Fax: (716) 684-4703

*ICP® is a registered trademark of PCB Group, Incorporated,  
which uniquely identifies PCB sensors that incorporate built-in microelectronics.*

Model Number <b>640B72</b>	<b>4-20 MA OUTPUT VELOCITY SENSOR</b>	Revision: C ECN #: 33907
-------------------------------	---------------------------------------	-----------------------------

	<b>ENGLISH</b>	<b>SI</b>	
<b>Performance</b>			
Measurement Range	0.0 to 2 in/sec pk	0.0 to 50.8 mm/s pk	[1]
Output	4-20 mA	4-20 mA	
Frequency Range(± 3 dB)	180 to 60,000 cpm	3 to 1000 Hz	[2][3]
Broadband Resolution	0.01 in/sec pk	0.26 mm/s pk	[4]
Non-Linearity	± 1 %	± 1 %	
<b>Environmental</b>			
Temperature Range	-40 to 185 °F	-40 to 85 °C	
<b>Electrical</b>			
Excitation Voltage	12 to 30 VDC	12 to 30 VDC	
Settling Time(within 2% of value)	<15 sec	<15 sec	
Electrical Isolation(Case)	>10 <sup>8</sup> ohm	>10 <sup>8</sup> ohm	
<b>Physical</b>			
Size (Hex x Height)	1.5 in x 3.7 in	38.1 mm x 94 mm	
Weight	19.5 oz	553 gm	
Mounting Thread	1/4 NPT	No Metric Equivalent	
Sensing Element	Ceramic	Ceramic	
Sensing Geometry	Shear	Shear	
Housing Material	Stainless Steel	Stainless Steel	
Electrical Connector	Removable Screw Terminals	Removable Screw Terminals	
Electrical Connection Position	Top	Top	
Electrical Connections(Tab 1)	4-20 mA Pos (+)	4-20 mA Pos (+)	
Electrical Connections(Tab 2)	4-20 mA Neg (-)	4-20 mA Neg (-)	
Screw Terminal Wire Size	12-24 AWG	3.0 - .2mm <sup>2</sup>	



All specifications are at room temperature unless otherwise specified.  
 In the interest of constant product improvement, we reserve the right to change specifications without notice.  
 ICP® is a registered trademark of PCB Group, Inc.

<b>OPTIONAL VERSIONS</b>		
Optional versions have identical specifications and accessories as listed for the standard model except where noted below. More than one option may be used.		
<b>EP</b> - Explosion-proof certified conduit housing with 1" pipe thread		
<b>HT</b> - High temperature, extends normal operation temperatures [6]		
Temperature Range	-40 to 275 °F	-40 to 125 °C
<b>RV</b> - Buffered Analog Signal Output - 100 mV/g (±20%)		
Electrical Connector	Removable Screw Terminals	Removable Screw Terminals
Electrical Connections(Tab 1)	4-20 mA Pos (+)	4-20 mA Pos (+)
Electrical Connections(Tab 2)	4-20 mA Neg (-)	4-20 mA Neg (-)
Electrical Connections(Tab 3)	Signal Output Pos	Signal Output Pos
Electrical Connections(Tab 4)	Signal Output Neg	Signal Output Neg
<b>TO</b> - Temperature Output [7]		
Temperature Output Range	-40 to +125 °C	-40 to +125 °C
Electrical Connector	Removable Screw Terminals	Removable Screw Terminals
Electrical Connections(Tab 1)	Vibration, 4-20 mA Pos.	Vibration, 4-20 mA Pos.
Electrical Connections(Tab 2)	Vibration, 4-20 mA Neg.	Vibration, 4-20 mA Neg.
Electrical Connections(Tab 3)	Temperature, 4-20 mA Pos.	Temperature, 4-20 mA Pos.
Electrical Connections(Tab 4)	Temperature, 4-20 mA Neg.	Temperature, 4-20 mA Neg.
<b>VO</b> - Buffered Analog Signal Output 100 mV/in/sec (±20%) [8]		
Electrical Connections(Tab 1)	Vibration, 4-20 mA Pos.	Vibration, 4-20 mA Pos.
Electrical Connections(Tab 2)	Vibration, 4-20 mA Neg.	Vibration, 4-20 mA Neg.
Electrical Connections(Tab 3)	Signal Output Pos	Signal Output Pos
Electrical Connections(Tab 4)	Signal Output Neg	Signal Output Neg
Electrical Connector	Terminal Block	Terminal Block

**NOTES:**  
 [1] Conversion Factor 1 in/sec = 0.0254 m/sec.  
 [2] Current will fluctuate at frequencies below 5 Hz.  
 [3] 1Hz = 60 cpm (cycles per minute).  
 [4] Typical.  
 [5] See PCB Declaration of Conformance PS039 for details.  
 [6] Can not be combined with EX or VO options.  
 [7] Can not be combined with RV or VO options.  
 [8] Can not be combined with EX, HT, TO , RV options.

**SUPPLIED ACCESSORIES:**  
 Model ICS-4 NIST-traceable single-axis amplitude response calibration from 0 cpm (0 Hz) to upper 10% frequency for 4 - 20 mA output vibration sensor (1)

Entered: <i>pmw</i>	Engineer: <i>Dgo</i>	Sales: <i>mm</i>	Approved: <i>Dgo</i>	Spec Number:
Date: <i>9/1/10</i>	Date: <i>9/1/10</i>	Date: <i>9/1/10</i>	Date: <i>9/1/10</i>	34414

**IMI SENSORS**  
 A PCB PIEZOTRONICS DIV.  
 3425 Walden Avenue, Depew, NY 14043

Phone: 800-959-4464  
 Fax: 716-684-3823  
 E-Mail: imi@pcb.com

**ATEX Approved Sensors**  
Vibration Sensors (4-20mA)  
(EX64XB7 Series)

**English**

This sensor has been approved for Hazardous Locations Directive 94/9/EC, Ex ia IIC T4 and Ex nA IIC T4.

For safe use:

- All applicable local electrical laws must be followed
- For "ia" installation, apparatus must only be connected to a certified associated intrinsically safe equipment and this combination must be compatible as regards intrinsic safety rules ( See Figure 1 )
- For "nA" installation, the supply electrical parameters shall not exceed values in Figure 2.
- Ambient operating temperature range:
  - o -40°C to +80°C

**Deutsch**

Die Sensoren der o. g. Serie wurden gemäß der EU-Richtlinie 94/9/EC, Ex ia IIC T4 und Ex nA IIC T4 ("Komponenten und Schutzsysteme für explosionsgefährdete Bereiche") zertifiziert.

Für den ordnungsgemäßen und sicheren Betrieb:

- müssen alle gültigen Gesetze und Vorschriften eingehalten werden
- Für „ia“ Installation, Apparat muss nur zu einen bescheinigten verbundenen inhärent sicheren Ausrüstungen verbunden werden und diese Kombination muss vereinbar sein, während inhärente Sicherheitsregeln betrachtet (Sehen Abbildung 1)
- Für „nA“ Installation wird die Versorgung elektrische Parameter Werte in Abbildung 2 nicht überschreiten.
- Umgebungstemperaturbereich:
  - o -40°C to +80°C

**Français**

Ce détecteur a été approuvé pour les Emplacements Hasardeux Directif 94/9/EC, Ex ia IIC T4 et Ex nA IIC T4.

Pour l'usage sûr :

- Toutes lois électriques, locales et applicables doivent être suivies
- Pour l'installation de « ia », l'appareil doit être seulement connecté à un équipement intrinsèquement sûr, associé et certifié et cette combinaison doit être compatible comme considère des mesures de sécurité intrinsèques (Voit la Figure 1)
- Pour l'installation de « nA », la provision les paramètres électriques ne dépasseront pas de valeur dans la Figure 2.
- La gamme de température d'opération Ambiante :
  - o -40°C to +80°C

**Italiano**

Questo sensore è stato approvato per le Posizioni Pericolose Direttivo 94/9/EC, Ex ia IIC T4 e Ex nA IIC T4.

Per l'uso sicuro:

- Tutte le leggi applicabili, locali elettriche devono essere seguite
- Per l'installazione di "ia", il dispositivo deve essere solo collegato a un'apparecchiatura certificata, associata intrinsecamente sicura e questa combinazione deve essere compatibile come considera le regole di sicurezza intrinseche (Vede l'illustrazione 1)
- Per l'installazione di "nA", la provvista i parametri elettrici non eccederanno di valori nell'illustrazione 2.
- la gamma di temperatura di funzionamento di Ambiente:
  - o -40°C to +80°C

**Español**

Este sensor se ha aprobado para Ubicaciones Peligrosas Directivas 94/9/EC, Ex ia IIC T4 y Ex nA IIC T4.

Para el uso seguro:

- Todas leyes eléctricas, locales y aplicables se deben seguir
- Para la instalación de "ia", el aparato sólo debe ser conectado a un equipo intrínsecamente seguro, asociado y certificado y esta combinación debe ser compatible considera como reglas intrínsecas de seguridad (Ve Figura 1)
- Para la instalación de "nA", el suministro parámetros eléctricos no excederán valores en la Figura 2.
- El Ambiente que opera la gama de la temperatura:
  - o -40°C to +80°C

**Русский**

Директивой 94/9/ЕС настоящий датчик разрешен к применению по категориям, Ex ia IIC T4 и Ex nA IIC T4.

Для безопасного использования:

- все правила электробезопасности должны быть выполнены.
- Для "ia" установки, аппарат должен только быть связан с гарантированным связанным свойственно безопасным оборудованием, и эта комбинация должна быть совместимой, что касается свойственных правил безопасности (См. иллюстрацию 1),
- Для "nA" установки, поставка электрические параметры не должны превышать ценности в иллюстрации 2.
- Диапазон рабочих температур:
  - o -40°C to +80°C

### Norsk

Denne sensoren godkjenner for Farlige Plasseringer Direktiv 94/9/EC, Ex ia IIC T4 og Ex nA IIC T4.

For sikker bruk:

- Alle anvendelige lokale elektriske lover fulgt
- For «ia» installasjon, apparat må bare bli koplet til et sertifisert tilknyttet indre sikkert utstyr og denne kombinasjonen må være forenelig med hensyn til indre sikkerhetsregel (Se Figur 1)
- For «nA» installasjon skal ikke overskride forsyningen elektriske parameterverdier i Figur 2.
- Omgivende betjeningsav temperaturrekkevidde:
  - o -40°C to +80°C

### Nederlands

Deze sensor is voor Gevaarlijke Locaties Leidinggevende 94/9/EC, Ex ia IIC T4 en Ex nA IIC T4 goedgekeurd worden.

Voor veilige gebruik:

- Alle toepasbare plaatselijke elektrische wetten moeten gevolgd worden
- For «ia» installation, apparat skal bare forbindes til et attesteret forbundet indrt sikkert udstyr og denne kombination må være forenelig som hensyn indrt sikkerhedsreler (Se Figur 1)
- For «nA» installation skal ikke overskride forsyningen elektriske parameterværdier i Figur 2.
- Het omgevend bediening temperatuur bereik:
  - o -40°C to +80°C

### Polski

Ten sensor ma być uznany pod kątem Hazardowy Rozmieszczenia Kierujący 94/9/EC Ex ia IIC T4 i Ex nA IIC T4.

Pod kątem kasa używać :

- Wszystko stosowny miejscowy elektryczny łąwsk musi być nastąpił
- W przypadku "ia" urządzenie, aparat musi jedynie zostać połączony z kwalifikowanego nieodłącznie związane z tym bezpieczne urządzenia i to połączenie musi być zgodne w odniesieniu do specyficznych zasad bezpieczeństwa (patrz: Wykres 1)
- Za "dot." instalacji, na dostawę sprzętu elektrycznego parametry nie powinny przekraczać wartości na rys. 2.
- Otaczający pracy temperatura rząd :
  - o -40°C to +80°C

### Português

Este sensor foi aprovado para a Diretiva 94/9/EC de Posições Arriscada, Ex ia IIC T4 e Ex nA IIC T4.

Para uso seguro:

- Todas as leis elétricas locais aplicáveis devem ser seguidas
- Para instalação de "ia", aparelho só deve ser ligado a um associado equipamento seguro certificado, intrinsecamente e esta combinação deve ser compatível como considera regras intrínsecas de segurança (Vê Figura 1)
- Para instalação de "nA", o estoque parâmetros eléctricos não excederão valores em Figura 2.
- Variedade de temperatura operacional ambiente:
  - o -40°C to +80°C

### Svensk

Den här sensoren er blitt gillat för Riskabel Lokaliseringarna Direktiv 94/9/ EC Ex ia IIC T4 och Ex nA IIC T4.

För kassaskåp använda :

- All användbar lokal elektrisk lag måste bli följde efter
- För "ia" installation, apparat måste bara kopplas till en intygad sig förbundet inre säker utrustning och denna kombination måste vara kompatibel då anser inre säkerhet regler (se Siffr 1)
- För "nA" installation, ska tillgångarna elektriska parametrarna inte överstiga värden i Siffr 2.
- Omgivande opera- temperatur ställa i rad :
  - o -40°C to +80°C

Figure 1:

MODEL	Ui(V)	Ii(mA)	Pi(W)	Ci(nF)	Li(uH)
EX64xB7y	30	100	1	0	1.06
EXT064xB7y, EXRV64xB7y	30	120	1	0	1.06

Figure 2:

MODEL	Ui(V)	Ii(mA)	Pi(W)	Ci(nF)	Li(uH)
EX64xB7y	12 to 30				
EXT064xB7y, EXRV64xB7y	12 to 30				

2

1

PCB Piezotronics Inc. claims proprietary rights in the information disclosed hereon. Neither it nor any reproduction thereof will be disclosed to others without the written consent of PCB Piezotronics Inc.

REVISIONS

REV	DESCRIPTION	DIN
D	CHANGE BRACKETS TO METRIC DIMENSIONS	35186

28148

RELATED DRAWING

NO MODIFICATIONS PERMITTED WITHOUT THE APPROVAL OF THE AUTHORIZED PERSON

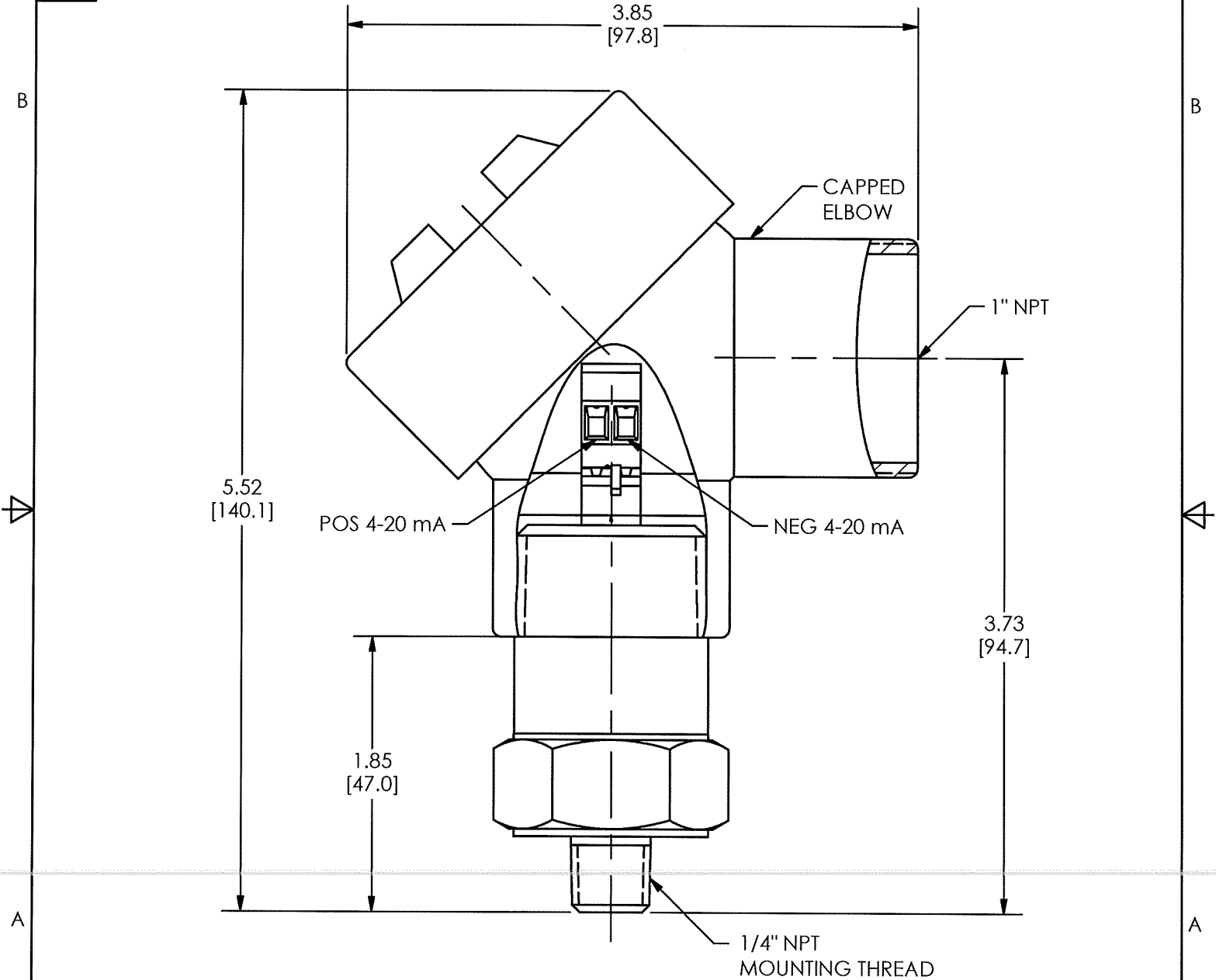

UNLESS OTHERWISE SPECIFIED TOLERANCES ARE:		DRAWN	CHECKED	ENGINEER	 <b>PCB PIEZOTRONICS</b> <small>INC.</small> 3425 WALDEN AVE. DEPEW, NY 14043 (716) 684-0001 E-MAIL: sales@pcb.com
DIMENSIONS IN INCHES	DIMENSIONS IN MILLIMETERS [IN BRACKETS]	<i>MDF</i> 3/3/11	<i>ECB</i> 3/4/11	JDK 3/3/11	
DECIMALS XX ±.03 XXX ±.010	DECIMALS X ±.8 XX ±.25	TITLE		CODE IDENT. NO. 52681	
ANGLES ± 2 DEGREES	ANGLES ± 2 DEGREES	OUTLINE DRAWING MODEL EP64XB7X, EX64XB7X 4-20 mA VELOCITY SENSOR		DWG. NO. 28148	
FILLETS AND RADII .003 - .005	FILLETS AND RADII 0.07 - 0.13			SCALE: FULL	SHEET 1 OF 1

2

1



LCIE

1 ATTESTATION D'EXAMEN CE DE TYPE

- 2 Appareils et systèmes de protection destinés à être utilisés en atmosphères explosibles  
Directive 94/9/CE
- 3 Numéro de l'attestation d'examen CE de type  
LCIE 06 ATEX 6154 X
- 4 Appareil ou système de protection :  
Capteurs de vibrations  
Type : EX64...,EXT064...,EXRV64 (voir page suivante)
- 5 Demandeur : I.M.I. (Industrial Monitoring Instrumentation)
- 6 Adresse : A PCB PIEZOTRONICS DIVISION  
3425 Walden Avenue  
Depew, New York 14043  
U.S.A.
- 7 Cet appareil ou système de protection et ses variantes éventuelles acceptées est décrit dans l'annexe de la présente attestation et dans les documents descriptifs cités en annexe.
- 8 Le LCIE, organisme notifié sous la référence 0081 conformément à l'article 9 de la directive 94/9/CE du Parlement européen et du Conseil du 23 mars 1994, certifie que cet appareil ou système de protection est conforme aux exigences essentielles en ce qui concerne la sécurité et la santé pour la conception et la construction d'appareils et de systèmes de protection destinés à être utilisés en atmosphères explosibles, données dans l'annexe II de la directive. Les vérifications et épreuves figurent dans nos rapports confidentiels n° 60040901/540946/1.
- 9 Le respect des exigences essentielles en ce qui concerne la sécurité et la santé est assuré par la conformité aux documents suivants  
-EN 50014 (1997) + amendements 1 et 2,  
-EN 50020 (2002)
- 10 Le signe X lorsqu'il est placé à la suite du numéro de l'attestation, indique que ce matériel ou système de protection est soumis aux conditions spéciales pour une utilisation sûre, mentionnées dans l'annexe de la présente attestation.
- 11 Cette attestation d'examen CE de type concerne uniquement la conception et la construction de l'appareil ou du système de protection spécifié, conformément à la directive 94/9/CE. Des exigences supplémentaires de cette directive sont applicables pour la fabrication et la fourniture de l'appareil ou du système de protection.
- 12 Le marquage de l'appareil ou du système de protection devra comporter, entre autres indications utiles, les mentions suivantes :  
 II 1 G  
EEx ia IIC T4

Fontenay-aux-Roses le 7 décembre 2005

1 EC TYPE EXAMINATION CERTIFICATE

- 2 Equipment or protective system intended for use in potentially explosive atmospheres  
Directive 94/9/EC
- 3 EC type Examination Certificate number  
LCIE 06 ATEX 6154 X
- 4 Equipment or protective system :  
Vibration sensors  
Type : EX64...,EXT064...,EXRV64... (see following page)
- 5 Applicant : I.M.I. (Industrial Monitoring Instrumentation)
- 6 Address : A PCB PIEZOTRONICS DIVISION  
3425 Walden Avenue  
Depew, New York 14043  
U.S.A.
- 7 This equipment or protective system and any acceptable variation thereto is specified in the schedule to this certificate and the documents therein referred to.
- 8 LCIE, notified body number 0081 in accordance with article 9 of the Directive 94/9/EC of the European Parliament and Council of 23 March 1994, certifies that this equipment or protective system has been found to comply with the essential Health and Safety Requirements relating to the design and construction of equipment and protective system intended for use in potentially explosive atmospheres, given in Annex II of the Directive. The examination and test results are recorded in confidential reports n° 60040901/540946/1.
- 9 Compliance with the Essential Health and Safety Requirements has been assured by compliance with :  
-EN 50014 (1997) + amendments 1 and 2,  
-EN 50020 (2002).
- 10 If the sign X is placed after the certificate number, it indicates that the equipment or protective system is subject to special conditions for safe use specified in the schedule to this certificate.
- 11 This EC Type examination certificate relates only to the design and construction of this specified equipment or protective system in accordance with the Directive 94/9/EC. Further requirements of the Directive applies to the manufacture and supply of this equipment or protective system.
- 12 The marking of the equipment or protective system shall include the following :  
 II 1 G  
EEx ia IIC T4

Le Directeur de l'organisme certificateur  
Manager of the certification body

Henri CERVELLO  
Timbre sec / Dry seal



LCIE

(A1) ANNEXE

(A1) SCHEDULE

(A2) ATTESTATION D'EXAMEN CE DE TYPE

(A2) EC TYPE EXAMINATION CERTIFICATE

LCIE 05 ATEX 6154 X

LCIE 05 ATEX 6154 X

(A3) Description de l'équipement ou du système de protection :

(A3) Description of Equipment or Protective System :

Capteurs de vibrations  
Type : EX64...,EXTO64...,EXRV64

Vibration sensors  
Type : EX64...,EXTO64...,EXRV64

Ce capteur est composé d'un ensemble piezo-cristal, d'une carte électronique et d'un connecteur ou un câble intégré.

This apparatus is made of a piezo-crystal assembly, an electronic board and a connector or an integrated cable.

Modèles concernés :

EX64xB0y, EX64xB1y, EX64xB6y,  
EXTO64xB3y, EXTO64xB1y, EXTO64xB6y,  
EXRV64xB0y, EXRV64xB1y, EXRV64xB6y,  
EX64xB7y, EXTO64xB7y, EXRV64xB7y  
EX64xA0y, EX64xA1y, EX64xA6y,  
EXTO64xA3y, EXTO64xA1y, EXTO64xA6y,  
EXRV64xA0y, EXRV64xA1y, EXRV64xA6y

Models concerned :

EX64xB0y, EX64xB1y, EX64xB6y,  
EXTO64xB3y, EXTO64xB1y, EXTO64xB6y,  
EXRV64xB0y, EXRV64xB1y, EXRV64xB6y,  
EX64xB7y, EXTO64xB7y, EXRV64xB7y  
EX64xA0y, EX64xA1y, EX64xA6y,  
EXTO64xA3y, EXTO64xA1y, EXTO64xA6y,  
EXRV64xA0y, EXRV64xA1y, EXRV64xA6y

Le marquage est le suivant :

Marking is as follow :

I.M.I. Adresse : ...  
Type : EX... (1)  
N° de fabrication : ... Année de fabrication : ...  
II 1 G EEx ia IIC T4  
LCIE 05 ATEX 6154 X  
T.amb. : - 40°C à + 80°C

I.M.I. Address : ...  
Type : EX... (1)  
Serial number : ... Year of manufacturing : ...  
II 1 G EEx ia IIC T4  
LCIE 05 ATEX 6154 X  
T.amb. : - 40°C to + 80°C

(1) Suivant le modèle

(1) According to the model

Le marquage CE est accompagné du numéro d'identification de l'organisme notifié responsable de la surveillance du système approuvé de qualité (0081 pour le LCIE).

The CE marking shall be accompanied by the identification number of the notified body responsible for surveillance of the approved quality system (0081 for LCIE).

Le matériel devra également comporter le marquage normalement prévu par les normes de construction du matériel électrique concerné.

The equipment must also bear the usual marking required by the manufacturing standards applying to such equipments.

Paramètres électriques relatifs à la sécurité :

Electrical parameters relative to safety :

Modèle / Model	Ui (V)	Ii (mA)	Pi (W)	Ci (nF)	Li (µH)
EX64xA0x, EX64xB0y	30	100	1	0	1,06
EX64xA1y, EX64xA6y, EX64xB1y, EX64xB6y	30	100	1	61	306
EXTO64xA3y, EXTO64xB3y	28	120	1	0	1,06
EXTO64xA1y, EXTO64xA6y, EXTO64xB1y, EXTO64xB6y	28	120	1	61	306
EXRV64xA0y, EXRV64xB0y	28	120	1	0	121,06
EXRV64xA1y, EXRV64xA6y, EXRV64xB1y, EXRV64xB6y	28	120	1	61	426
EX64xB7y	30	100	1	0	1,06
EXTO64xB7y, EXRV64xB7y	30	120	1	0	1,06



LCIE

**(A1) ANNEXE**

**(A1) SCHEDULE**

**(A2) ATTESTATION D'EXAMEN CE DE TYPE**

**(A2) EC TYPE EXAMINATION CERTIFICATE**

**LCIE 05 ATEX 6154 X (suite)**

**LCIE 05 ATEX 6154 X (continued)**

**(A4) Documents descriptifs :**

Dossier technique N° 28770 Rév. NR du 10/10/2005.  
Ce document comporte 12 rubriques (28 pages).

Dossier technique N° 27866 Rév. NR du 10/10/2005.  
Ce document comporte 18 rubriques (37 pages).

**(A4) Descriptive documents :**

Technical file No. 28770 Rev. NR dated 10/10/2005.  
This file includes 12 items (28 pages).

Technical file No. 27866 Rev. NR dated 10/10/2005.  
This file includes 18 items (37 pages).

**(A5) Conditions spéciales pour une utilisation sûre :**

Ce matériel est un appareil de sécurité intrinsèque, il peut être placé en atmosphère explosible.

Le matériel ne doit être raccordé qu'à un matériel associé de sécurité intrinsèque certifié et cette association doit être compatible du point de vue sécurité intrinsèque (voir paramètres électriques au paragraphe (A3)).

Température ambiante d'utilisation : - 40°C à + 80°C.

**(A5) Special conditions for safe use :**

This equipment is an intrinsically safe apparatus, it can be mounted in explosive atmosphere.

The apparatus must be only connected to a certified associated intrinsically safe equipment and this combination must be compatible regarding intrinsic safety rules (see electrical parameters clause (A3)).

Operating ambient temperature : - 40°C to + 80°C.

**(A6) Exigences essentielles en ce qui concerne la sécurité et la santé :**

Conformité aux normes européennes EN 50014 (1997 + amendements 1 et 2) et EN 50020 (2002).

**Vérifications et épreuves individuelles :**

L'appareil est dispensé d'épreuve individuelle.

**(A6) Essential Health and Safety Requirements :**

Conformity to the European standards EN 50014 (1997 + amendments 1 and 2) and EN 50020 (2002).

**Individual examinations and tests :**

The equipment is not submitted to routine test.



LCIE

**1 ATTESTATION D'EXAMEN DE TYPE**

2 Appareils et systèmes de protection destinés à être utilisés en atmosphères explosibles  
Directive 94/9/CE

3 Numéro de l'attestation d'examen de type  
LCIE 05 ATEX 6155 X

4 Appareil ou système de protection :  
Capteurs de vibrations  
Type : EX64...,EXTO64...,EXRV64 (voir page suivante)

5 Demandeur : I.M.I. (Industrial Monitoring Instrumentation)

6 Adresse : A PCB PIEZOTRONICS DIVISION  
3425 Walden Avenue  
Depew, New York 14043  
U.S.A.

7 Cet appareil ou système de protection et ses variantes éventuelles acceptées est décrit dans l'annexe de la présente attestation et dans les documents descriptifs cités en annexe.

8 Le LCIE certifie que cet appareil ou système de protection est conforme aux exigences essentielles en ce qui concerne la sécurité et la santé pour la conception et la construction d'appareils et de systèmes de protection destinés à être utilisés en atmosphères explosibles, données dans l'annexe II de la directive. Les vérifications et épreuves figurent dans nos rapports confidentiels n° 60040901/540946/2.

9 Le respect des exigences essentielles en ce qui concerne la sécurité et la santé est assuré par la conformité aux documents suivants :

-EN 50021 (1999)

10 Le signe X lorsqu'il est placé à la suite du numéro de l'attestation, indique que ce matériel ou système de protection est soumis aux conditions spéciales pour une utilisation sûre, mentionnées dans l'annexe de la présente attestation.

11 Cette attestation d'examen de type concerne uniquement la conception et la construction de l'appareil ou du système de protection spécifié, conformément à la directive 94/9/CE. Des exigences supplémentaires de cette directive sont applicables pour la fabrication et la fourniture de l'appareil ou du système de protection.

12 Le marquage de l'appareil ou du système de protection devra comporter, entre autres indications utiles, les mentions suivantes :

II 3 G  
EEx nL ou nA IIC T4

**1 TYPE EXAMINATION CERTIFICATE**

2 Equipment or protective system intended for use in potentially explosive atmospheres  
Directive 94/9/EC

3 Type Examination Certificate number  
LCIE 05 ATEX 6155 X

4 Equipment or protective system :  
Vibration sensors  
Type : EX64...,EXTO64...,EXRV64... (see following page)

5 Applicant : I.M.I. (Industrial Monitoring Instrumentation)

6 Address : A PCB PIEZOTRONICS DIVISION  
3425 Walden Avenue  
Depew, New York 14043  
U.S.A.

7 This equipment or protective system and any acceptable variation thereto is specified in the schedule to this certificate and the documents therein referred to.

8 LCIE certifies that this equipment or protective system has been found to comply with the essential Health and Safety Requirements relating to the design and construction of equipment and protective system intended for use in potentially explosive atmospheres, given in Annex II of the Directive. The examination and test results are recorded in confidential reports n° 60040901/540946/2.

9 Compliance with the Essential Health and Safety Requirements has been assured by compliance with :

-EN 50021 (1999)

10 If the sign X is placed after the certificate number, it indicates that the equipment or protective system is subject to special conditions for safe use specified in the schedule to this certificate.

11 This type examination certificate relates only to the design and construction of this specified equipment or protective system in accordance with the Directive 94/9/EC. Further requirements of the Directive applies to the manufacture and supply of this equipment or protective system.

12 The marking of the equipment or protective system shall include the following :

II 3 G  
EEx nL or nA IIC T4

Fontenay-aux-Roses, le 7 décembre 2005

Le Directeur de l'organisme certificateur  
Manager of the certification body

Henri CERVELLO  
Timbre sec / Dry seal

Seul le texte en français peut engager la responsabilité du LCIE. Ce document ne peut être reproduit que dans son intégralité, sans aucune modification  
The LCIE's liability applies only on the French text. This document may be reproduced in full and without any change

Page 1/3



(A1) ANNEXE

(A1) SCHEDULE

(A2) ATTESTATION D'EXAMEN DE TYPE

(A2) TYPE EXAMINATION CERTIFICATE

LCIE 05 ATEX 6155 X

LCIE 05 ATEX 6155 X

(A3) Description de l'équipement ou du système de protection :

(A3) Description of Equipment or Protective System :

Capteurs de vibrations  
Type : EX64...,EXTO64...,EXRV64

Vibration sensors  
Type : EX64...,EXTO64...,EXRV64

Ce capteur est composé d'un ensemble piezo-cristal, d'une carte électronique et d'un connecteur ou un câble intégré.

This apparatus is made of a piezo-crystal assembly, an electronic board and a connector or an integrated cable.

Modèles concernés :  
EX64xB0y, EX64xB1y, EX64xB6y  
EXTO64xB3y, EXTO64xB1y, EXTO64xB6y,  
EXRV64xB0y, EXRV64xB1y, EXRV64xB6y,  
EX64xB7y, EXTO64xB7y, EXRV64xB7y  
EX64xA0y, EX64xA1y, EX64xA6y,  
EXTO64xA3y, EXTO64xA1y, EXTO64xA6y,  
EXRV64xA0y, EXRV64xA1y, EXRV64xA6y

Models concerned :  
EX64xB0y, EX64xB1y, EX64xB6y  
EXTO64xB3y, EXTO64xB1y, EXTO64xB6y,  
EXRV64xB0y, EXRV64xB1y, EXRV64xB6y,  
EX64xB7y, EXTO64xB7y, EXRV64xB7y  
EX64xA0y, EX64xA1y, EX64xA6y,  
EXTO64xA3y, EXTO64xA1y, EXTO64xA6y,  
EXRV64xA0y, EXRV64xA1y, EXRV64xA6y

Le marquage est le suivant :

Marking is as follow :

I.M.I. Adresse : ...  
Type : EX... (1)  
N° de fabrication : ... Année de fabrication : ...  
⊕ II 3 G  
EEx nL IIC T4  
EEx nA IIC T4 (types EX64xB7y, EXTO64xB7y, EXRV64xB7y)  
LCIE 05 ATEX 6155 X  
T.amb. : - 40°C à + 80°C

I.M.I. Address : ...  
Type : EX... (1)  
Serial number : ... Year of manufacturing : ...  
⊕ II 3 G  
EEx nL IIC T4  
EEx nA IIC T4 (types EX64xB7y, EXTO64xB7y, EXRV64xB7y)  
LCIE 05 ATEX 6155 X  
T.amb. : - 40°C to + 80°C

(1) Suivant le modèle

(1) According to the model

Le matériel devra également comporter le marquage normalement prévu par les normes de construction du matériel électrique concerné.

The equipment must also bear the usual marking required by the manufacturing standards applying to such equipments.

Paramètres électriques relatifs à la sécurité :

Electrical parameters relative to safety :

Modèle / Model	Ui (V)	Ii (mA)	PI (W)	Ci (nF)	Li (µH)
EX64xA0x, EX64xB0y	30	100	1	0	1,06
EX64xA1y, EX64xA6y, EX64xB1y, EX64xB6y	30	100	1	61	306
EXTO64xA3y, EXTO64xB3y	28	120	1	0	1,06
EXTO64xA1y, EXTO64xA6y, EXTO64xB1y, EXTO64xB6y	28	120	1	61	306
EXRV64xA0y, EXRV64xB0y	28	120	1	0	121,06
EXRV64xA1y, EXRV64xA6y, EXRV64xB1y, EXRV64xB6y	28	120	1	61	426
EX64xB7y	12 à/à 30	/	/	/	/
EXTO64xB7y, EXRV64xB7y	12 à/à 30	/	/	/	/



(A1) ANNEXE

(A1) SCHEDULE

(A2) ATTESTATION D'EXAMEN DE TYPE

(A2) TYPE EXAMINATION CERTIFICATE

LCIE 05 ATEX 6155 X (suite)

LCIE 05 ATEX 6155 X (continued)

(A4) Documents descriptifs :

(A4) Descriptive documents :

Dossier technique N° 28771 Rév. NR du 10/10/2005.  
Ce document comporte 12 rubriques (28 pages).

Technical file No. 28771 Rev. NR dated 10/10/2005.  
This file includes 12 items (28 pages).

Dossier technique N° 27867 Rév. NR du 10/10/2005.  
Ce document comporte 18 rubriques (37 pages).

Technical file No. 27867 Rev. NR dated 10/10/2005.  
This file includes 18 items (37 pages).

(A5) Conditions spéciales pour une utilisation sûre :

(A5) Special conditions for safe use :

Les paramètres électriques d'alimentation ne doivent pas excéder les valeurs mentionnées au paragraphe (A3).

The supply electrical parameters shall not exceed the values mentioned in paragraph (A3).

Température ambiante d'utilisation : - 40°C à + 80°C.

Operating ambient temperature : - 40°C to + 80°C.

(A6) Exigences essentielles en ce qui concerne la sécurité et la santé :

(A6) Essential Health and Safety Requirements :

Conformité au norme européenne EN 50021 (1999).

Conformity to the European standard EN 50021 (1999).

Vérifications et épreuves individuelles :

Individual examinations and tests :

L'appareil est dispensé d'épreuve individuelle.

The equipment is not submitted to routine test.



LCIE

**1 AVENANT D'ATTESTATION D'EXAMEN CE DE TYPE**

**2 Appareil ou système de protection destiné à être utilisé en atmosphères explosibles (Directive 94/9/CE)**

**3 Numéro de l'avenant :**  
LCIE 05 ATEX 6154 X / 01

**4 Appareil ou système de protection :**  
Capteurs de vibration  
Type : EX64..., EXTO64..., EXVR64...

**5 Demandeur :** I.M.I.

**15 DESCRIPTION DE L'AVENANT**

Mise à jour normative selon les normes EN 60079-0 (2006) et EN 60079-11 (2007).

Les résultats des vérifications et essais figurent dans le rapport confidentiel N° 60058689/559760

Paramètres spécifiques du ou des modes de protection concerné(s) :  
Inchangés

Le marquage doit être modifié comme suit :  
Ex la IIC T4

**16 DOCUMENTS DESCRIPTIFS**

Dossier de certification N° 27866 Rév. A du 27/06/2007.  
Ce dossier comprend 18 rubriques (37 pages).  
Dossier de certification N° 28770 Rév. A du 27/06/2007.  
Ce dossier comprend 12 rubriques (28 pages).

**17 CONDITIONS SPECIALES POUR UNE UTILISATION SURE**  
Inchangées

**18 EXIGENCES ESSENTIELLES DE SECURITE ET DE SANTE**  
Conformité aux normes européennes EN 60079-0 (2006) et EN 60079-11 (2007).

**19 VERIFICATIONS ET ESSAIS INDIVIDUELS**  
Néant

Fontenay-aux-Roses, le 2 août 2007

**1 SUPPLEMENTARY EC TYPE EXAMINATION CERTIFICATE**

**2 Equipment or protective system intended for use in potentially explosive atmospheres (Directive 94/9/EC)**

**3 Supplementary certificate number :**  
LCIE 05 ATEX 6154 X / 01

**4 Equipment or protective system :**  
Vibration sensors  
Type : EX64..., EXTO64..., EXVR64...

**5 Applicant :** I.M.I.

**15 DESCRIPTION OF THE SUPPLEMENTARY CERTIFICATE**  
Normative update according to EN 60079-0 (2006) and EN 60079-11 (2007) standards.

The examination and test results are recorded in confidential report N° 60058689/559760

Specific parameters of the mode(s) of protection concerned:  
Unchanged

The marking shall be modified as follows :  
Ex la IIC T4

**16 DESCRIPTIVE DOCUMENTS**

Certification file N° 27866 Rev. A dated 27/06/2007.  
This file includes 18 items (37 pages).  
Certification file N° 28770 Rév. A dated 27/06/2007.  
This file includes 12 items (28 pages).

**17 SPECIAL CONDITIONS FOR SAFE USE**  
Unchanged

**18 ESSENTIAL HEALTH AND SAFETY REQUIREMENTS**  
Conformity to the European standards EN 60079-0 (2006) and EN 60079-11 (2007).

**19 ROUTINE VERIFICATIONS AND TESTS**  
None

Le responsable de certification ATEX  
ATEX certification manager



*[Signature]*  
M. CERVELLO

Seul le texte en français peut engager la responsabilité du LCIE. Ce document ne peut être reproduit que dans son intégralité, sans aucune modification.  
The LCIE's liability applies only on the French text. This document may only be reproduced in its entirety and without any change.



LCIE

**1 AVENANT D'ATTESTATION D'EXAMEN CE DE TYPE**

**2 Appareil ou système de protection destiné à être utilisé en atmosphères explosibles (Directive 94/9/CE)**

**3 Numéro de l'avenant :**  
LCIE 06 ATEX 6156 X / 01

**4 Appareil ou système de protection :**  
Capteurs de vibration  
Type : EX64..., EXTO64..., EXVR64...

**5 Demandeur :** I.M.I.

**15 DESCRIPTION DE L'AVENANT**

Mise à jour normative selon les normes EN 60079-0 (2006) et EN 60079-15 (2005).

Les résultats des vérifications et essais figurent dans le rapport confidentiel N° 60056689/559762

Paramètres spécifiques du ou des modes de protection concerné(s) :  
Inchangés

Le marquage doit être modifié comme suit :  
Ex nL IIC T4  
Ex nA IIC T4 (pour EX64xB7y, EXTO64xB7y, EXRV64xB7y)

**16 DOCUMENTS DESCRIPTIFS**

Dossier de certification N° 27867 Rév. A du 27/06/2007.  
Ce dossier comprend 18 rubriques (37 pages).  
Dossier de certification N° 28771 Rév. A du 27/06/2007.  
Ce dossier comprend 12 rubriques (28 pages).

**17 CONDITIONS SPECIALES POUR UNE UTILISATION SURE**  
Inchangées

**18 EXIGENCES ESSENTIELLES DE SECURITE ET DE SANTE**  
Conformité aux normes européennes EN 60079-0 (2006) et EN 60079-15 (2005).

**19 VERIFICATIONS ET ESSAIS INDIVIDUELS**  
Néant

**1 SUPPLEMENTARY EC TYPE EXAMINATION CERTIFICATE**

**2 Equipment or protective system intended for use in potentially explosive atmospheres (Directive 94/9/EC)**

**3 Supplementary certificate number :**  
LCIE 06 ATEX 6156 X / 01

**4 Equipment or protective system :**  
Vibration sensors  
Type : EX64..., EXTO64..., EXVR64...

**5 Applicant :** I.M.I.

**15 DESCRIPTION OF THE SUPPLEMENTARY CERTIFICATE**  
Normative update according to EN 60079-0 (2006) and EN 60079-15 (2005) standards.

The examination and test results are recorded in confidential report N° 60056689/559762

Specific parameters of the mode(s) of protection concerned:  
Unchanged

The marking shall be modified as follows :  
Ex nL IIC T4  
Ex nA IIC T4 (for EX64xB7y, EXTO64xB7y, EXRV64xB7y)

**16 DESCRIPTIVE DOCUMENTS**

Certification file N° 27867 Rev. A dated 27/06/2007.  
This file includes 18 items (37 pages).  
Certification file N° 28771 Rév. A dated 27/06/2007.  
This file includes 12 items (28 pages).

**17 SPECIAL CONDITIONS FOR SAFE USE**  
Unchanged

**18 ESSENTIAL HEALTH AND SAFETY REQUIREMENTS**  
Conformity to the European standards EN 60079-0 (2006) and EN 60079-15 (2005).

**19 ROUTINE VERIFICATIONS AND TESTS**  
None

Fontenay-aux-Roses, le 2 août 2007

Le responsable de certification ATEX  
ATEX certification manager



*René Cervello*  
René CERVELLO

Seul le texte en français peut engager la responsabilité du LCIE. Ce document ne peut être reproduit que dans son intégralité, sans aucune modification.  
The LCIE's liability applies only on the French text. This document may only be reproduced in its entirety and without any change.

Page 1 sur 1

01A-Anness III\_CE\_1pp\_1pp\_sw - rev1.DOC

**EC Declaration of Conformity PS 053**  
*In Accordance with ISO/IEC 17050*

<b>Manufacturer:</b> PCB Piezotronics, Inc. 3425 Walden Avenue Depew, New York 14043 USA	<b>Authorized European Representative:</b> PCB Piezotronics Europe GmbH PO Box 1148 D-52473 Linnich, Germany
--	--

**Certifies that type of equipment:**      Vibration Sensor(s)

**Whose Product Models Include:**      EX64..., EXT064..., EXVR64... Series

This declaration is applicable to all Vibration Sensor(s) of the above series which have the CE & (EX) ATEX mark on their data sheets and where those data sheets refer to this declaration of conformity. The data sheets for all model numbers referenced above, which include the CE & (EX) ATEX mark on such data sheets and refer to this Declaration of Conformity are hereby incorporated by reference into this Declaration.

Conform to the following EC Directive(s) when installed per product documentation:	2004/108/EC 94/9/EC	EMC directive ATEX
--	------------------------	-----------------------

**Standards to which Conformity is Declared:**

<b>Harmonized Standards</b>	EN61326-1:2006 EN61326-2-3: 2006 EN61010-1:2001 EN60079-0 (2006) EN60079-11 (2007)	Electrical Equipment for Measurement, Control and Laboratory Use- EMC Electrical Equipment for Measurement, Control and Laboratory Use- EMC Safety Standard General Explosive Atmosphere Intrinsic safe, I
<b>Emissions Test Standards</b>	EN 55011 (2007)	Industrial, scientific and medical(ISM) radio frequency equipment Electromagnetic disturbance characteristics- Limits and methods of Measurement Class B
<b>Immunity Test Standards</b>	EN 61000-4-2:2001 EN 61000-4-3:2006 EN 61000-4-4:2004 EN 61000-4-5:2005 EN 61000-4-6:2006 EN 61000-4-8:2001	Electrostatic discharge (ESD) Radiated, radio-frequency, electromagnetic field immunity Electrical fast transient (EFT) / Burst immunity Surge immunity Immunity to RF conducted line disturbances Power frequency magnetic field immunity
<b>Test Reports</b>	EMC Reports Safety Reports  ATEX Cert	GM29045c GM29046s  LCIE 05 ATEX 6154 X / 01 Ex ia IIC T4, II 1G
<b>Notified Body Name</b>		Laboratoire Central des Industries Electriques (0081)
<b>Notified Body's Address</b>		<b>FONTENAY-AUX-ROSES (Head Office)</b> 33, avenue du Général Leclerc FR- 92260 Fontenay-aux-Roses Tel. : + 33 1 40 95 60 60 Fax : + 33 1 40 95 86 56

*I, the undersigned, hereby declare that the equipment specified above conforms to the above Directive(s) Standard(s)*

Place: Depew, NY    Date: 07/07/2010

Signature:   

---

 Name: Kenneth J. Gonyea Jr.  

---

 Title: V.P. Manufacturing  

---



# Certificate of Compliance

Certificate: 1632187

Master Contract: 184981

Project: 2655913

Date Issued: September 26, 2013

Issued to: Industrial Monitoring Instr. (IMI)

A Div. of PCB Piezotronics, Inc.  
3425 Walden Ave  
Depew, NY 14043  
USA  
Attention: Bill Hynd

*The products listed below are eligible to bear the CSA Mark shown with adjacent indicators 'C' and 'US' for Canada and US or with adjacent indicator 'US' for US only or without either indicator for Canada only.*



*Jelena Dzeletovic*

Issued by: Jelena Dzeletovic

## **PRODUCTS**

- CLASS 2258 83** - PROCESS CONTROL EQUIPMENT-Intrinsically Safe and Non-Incendive - Systems-For Hazardous Locations-Certified to U.S. Standards
- CLASS 2258 03** - PROCESS CONTROL EQUIPMENT - Intrinsically Safe and Non-Incendive Systems - For Hazardous Locations
- CLASS 2258 04** - PROCESS CONTROL EQUIPMENT - Intrinsically Safe, Entity - For Hazardous Locations
- CLASS 2258 84** - PROCESS CONTROL EQUIPMENT - Intrinsically Safe, Entity - - For Hazardous Locations - Certified to US Standards

**Class I, Div. 1, Groups A, B, C and D; Class II, Div. 1, Groups E, F and G; Class III, Div 1:**

**Exia IIC T4:**

**AEx ia IIC T4:**

Models EX64xB0y Vibration Sensors, input rated 28V dc max, 20mA; intrinsically safe with entity parameters of:  $U_i$  (V max) = 30V,  $I_i$  (I max) = 100mA,  $P_i$  = 1W,  $L_i$  = 1.06 uH,  $C_i$  = 0; when installed per installation Dwg 27534; Temp Code T4 @ Max Ambient 80 Deg C.

32674  
REV - E  
ECO - 42326



**Certificate:** 1632187

**Master Contract:** 184981

**Project:** 2655913

**Date Issued:** September 26, 2013

---

Models 9842VCRT Vibration Sensors, input rated 28V dc max, 20mA; intrinsically safe with entity parameters of:  $U_i$  (V max) = 30V,  $I_i$  (I max) = 100mA,  $P_i$  = 1W,  $C_i$  = 0,  $L_i$  = 1.06 uH; when installed per installation Dwg 36576; Temp Code T4 @ Max Ambient 80 Deg C.

Models EX64xB1y and EX64xB6y Vibration Sensors, input rated 28V dc max, 20mA; intrinsically safe with entity parameters of:  $U_i$  (V max) = 30V,  $I_i$  (I max) = 100mA,  $P_i$  = 1W,  $C_i$  = 61 nF,  $L_i$  = 306 uH; when installed per installation Dwg 27534; Temp Code T4 @ Max Ambient 80 Deg C.

Models EXTO64xB3y Vibration Sensors, input rated 28V dc max, 20mA; intrinsically safe with entity parameters of:  $U_i$  (V max) = 28V,  $I_i$  (I max) = 120mA,  $P_i$  = 1W,  $L_i$  = 1.06 uH,  $C_i$  = 0; when installed per installation Dwg 27536; Temp Code T4 @ Max Ambient 80 Deg C.

Models EXTO64xB1y and EXTO64xB6y Vibration Sensors, input rated 28V dc max, 20mA; intrinsically safe with entity parameters of:  $U_i$  (V max) = 28V,  $I_i$  (I max) = 120mA,  $P_i$  = 1W,  $C_i$  = 61 nF,  $L_i$  = 306 uH; when installed per installation Dwg 27536; Temp Code T4 @ Max Ambient 80 Deg C.

Models EXRV64xB0y Vibration Sensors, input rated 28V dc max, 20mA; intrinsically safe with entity parameters of:  $U_i$  (V max) = 28V,  $I_i$  (I max) = 120mA,  $P_i$  = 1W,  $L_i$  = 121.06 uH,  $C_i$  = 0; when installed per installation Dwg 30538; Temp Code T4 @ Max Ambient 80 Deg C.

Models EXRV64xB1y and EXRV64xB6y Vibration Sensors, input rated 28V dc max, 20mA; intrinsically safe with entity parameters of:  $U_i$  (V max) = 28V,  $I_i$  (I max) = 120mA,  $P_i$  = 1W,  $C_i$  = 61 nF,  $L_i$  = 426 uH; when installed per installation Dwg 30538; Temp Code T4 @ Max Ambient 80 Deg C.

Models EX64xB7y Vibration Sensors, input rated 28V dc max, 20mA; intrinsically safe with entity parameters of:  $U_i$  (V max) = 30V,  $I_i$  (I max) = 100mA,  $P_i$  = 1W,  $L_i$  = 1.06 uH,  $C_i$  = 0; when installed per installation Dwg 28766; Temp Code T4 @ Max Ambient 80 Deg C.

Models EXTO64xB7y Vibration Sensors, input rated 28V dc max, 20mA; intrinsically safe with entity parameters of:  $U_i$  (V max) = 28V,  $I_i$  (I max) = 120mA,  $P_i$  = 1W,  $L_i$  = 1.06 uH,  $C_i$  = 0; when installed per installation Dwg 28767; Temp Code T4 @ Max Ambient 80 Deg C.

Models EXRV64xB7y Vibration Sensors, input rated 28V dc max, 20mA; intrinsically safe with entity parameters of:  $U_i$  (V max) = 28V,  $I_i$  (I max) = 120mA,  $P_i$  = 1W,  $L_i$  = 1.06 uH,  $C_i$  = 0; when installed per installation Dwg 29987; Temp Code T4 @ Max Ambient 80 Deg C.

Note: The "x" in the model code may be a 0, 1, 5 or 6, which denotes variations in frequency response range of the sensors. The "y" in the model code may be a 0, 1 or 2, which denotes variations in sensor sensitivity.

Models EX64xA0y Vibration Sensors, input rated 28V dc max, 20mA; intrinsically safe with entity parameters of:  $U_i$  (V max) = 30V,  $I_i$  (I max) = 100mA,  $P_i$  = 1W,  $L_i$  = 1.06 uH,  $C_i$  = 0; when installed per installation Dwg 27535; Temp Code T4 @ Max Ambient 80 Deg C.

Models 9942VCRT Vibration Sensors, input rated 28V dc max, 20mA; intrinsically safe with entity parameters of:  $U_i$  (V max) = 30V,  $I_i$  (I max) = 100mA,  $P_i$  = 1W,  $C_i$  = 0,  $L_i$  = 1.06 uH; when installed per installation Dwg 36578; Temp Code T4 @ Max Ambient 80 Deg C.



**Certificate:** 1632187

**Master Contract:** 184981

**Project:** 2655913

**Date Issued:** September 26, 2013

---

Models EX64xA1y and EX64xA6y Vibration Sensors, input rated 28V dc max, 20mA; intrinsically safe with entity parameters of:  $U_i$  (V max) = 30V,  $I_i$  (I max) = 100mA,  $P_i$  = 1W,  $C_i$  = 61 nF,  $L_i$  = 306  $\mu$ H; when installed per installation Dwg 27535; Temp Code T4 @ Max Ambient 80 Deg C.

Models EXTO64xA3y Vibration Sensors, input rated 28V dc max, 20mA; intrinsically safe with entity parameters of:  $U_i$  (V max) = 28V,  $I_i$  (I max) = 120mA,  $P_i$  = 1W,  $L_i$  = 1.06 uH,  $C_i$  = 0; when installed per installation Dwg 27537; Temp Code T4 @ Max Ambient 80 Deg C.

Models EXTO64xA1y and EXTO64xA6y Vibration Sensors, input rated 28V dc max, 20mA; intrinsically safe with entity parameters of:  $U_i$  (V max) = 28V,  $I_i$  (I max) = 120mA,  $P_i$  = 1W,  $C_i$  = 61 nF,  $L_i$  = 306  $\mu$ H; when installed per installation Dwg 27537; Temp Code T4 @ Max Ambient 80 Deg C.

Models EXRV64xA0y Vibration Sensors, input rated 28V dc max, 20mA; intrinsically safe with entity parameters of:  $U_i$  (V max) = 28V,  $I_i$  (I max) = 120mA,  $P_i$  = 1W,  $L_i$  = 121.06 uH  $C_i$  = 0; when installed per installation Dwg 30540; Temp Code T4 @ Max Ambient 80 Deg C.

Models EXRV64xA1y and EXRV64xA6y Vibration Sensors, input rated 28V dc max, 20mA; intrinsically safe with entity parameters of:  $U_i$  (V max) = 28V,  $I_i$  (I max) = 120mA,  $P_i$  = 1W,  $C_i$  = 61 nF,  $L_i$  = 426  $\mu$ H; when installed per installation Dwg 30540; Temp Code T4 @ Max Ambient 80 Deg C.

Models CS64xB9y Vibration Sensors, input rated 28V dc max, 20mA; intrinsically safe with entity parameters of:  $U_i$  (V max) = 30V,  $I_i$  (I max) = 100mA,  $P_i$  = 1W,  $C_i$  = 0,  $L_i$  = 1.06 uH; when installed per Dwg 56140; Temp Code T4 @ Max Ambient 80 Deg C.

Note: The "x" in the model code may be a 2, 3, 7 or 8, which denotes variations in frequency response range of the sensors. The "y" in the model code may be a 0, 1 or 2, which denotes variations in sensor sensitivity.

## **APPLICABLE REQUIREMENTS**

CAN/CSA-C22.2 No. 0-M91 - General Requirements – Canadian Electrical Code, Part II

C22.2 No. 142-M1987(R2009) - Process Control Equipment

CAN/CSA-C22.2 No. 157-92(R2012) - Intrinsically Safe and Non-Incendive Equipment for Use in Hazardous Locations

UL 913 (7th Ed.) - Intrinsically Safe Apparatus and Associated Apparatus for Use in Class I, II and III, Division 1, Hazardous Locations

UL 916 (4th Ed.) - Energy Management Equipment

CAN/CSA-E60079-0:07 - Electrical apparatus for explosive gas atmospheres - Part 0: General Requirements

CAN/CSA-E60079-11:02 - Electrical apparatus for explosive gas atmospheres - Part 11: Intrinsic Safety "i"

ANSI/UL 60079-0:05- Electrical Apparatus for Explosive Gas Atmospheres - Part 0: General Requirements

ANSI/UL 60079-11:07 - Electrical apparatus for Explosive Gas Atmospheres - Part 11: Intrinsic Safety "i"



**Certificate:** 1632187

**Master Contract:** 184981

**Project:** 2655913

**Date Issued:** September 26, 2013

---

**CLASS 2258 03** - PROCESS CONTROL EQUIPMENT - Intrinsically Safe and Non-Incendive Systems - For Hazardous Locations

**CLASS 2258 83** - PROCESS CONTROL EQUIPMENT - Intrinsically Safe and Non-Incendive Systems - For Hazardous Locations - CERTIFIED TO U.S. STANDARDS

**Ex nL IICT4:**

**AEx nA IICT4:**

**Class I, Div. 2, Groups A, B, C, D:**

Models EX64xB0y Vibration Sensors, input rated 28V dc max, 20mA; non-incendive with entity parameters of:  $U_i$  (V max) = 30V,  $I_i$  (I max) = 100mA,  $P_i$  = 1W,  $L_i$  = 1.06 uH,  $C_i$  = 0; when installed per installation Dwg 27534; Temp Code T4 @ Max Ambient 80 Deg C.

Models 9842VCRT Vibration Sensors, input rated 28V dc max, 20mA; non-incendive with entity parameters of:  $U_i$  (V max) = 30V,  $I_i$  (I max) = 100mA,  $P_i$  = 1W,  $C_i$  = 0,  $L_i$  = 1.06 uH; when installed per installation Dwg 36576; Temp Code T4 @ Max Ambient 80 Deg C.

Models EX64xB1y and EX64xB6y Vibration Sensors, input rated 28V dc max, 20mA; non-incendive with entity parameters of:  $U_i$  (V max) = 30V,  $I_i$  (I max) = 100mA,  $P_i$  = 1W,  $C_i$  = 61 nF,  $L_i$  = 306 uH; when installed per installation Dwg 27534; Temp Code T4 @ Max Ambient 80 Deg C.

Models EXTO64xB3y Vibration Sensors, input rated 28V dc max, 20mA; non-incendive with entity parameters of:  $U_i$  (V max) = 28V,  $I_i$  (I max) = 120mA,  $P_i$  = 1W,  $L_i$  = 1.06 uH,  $C_i$  = 0; when installed per installation Dwg 27536; Temp Code T4 @ Max Ambient 80 Deg C.

Models EXTO64xB1y and EXTO64xB6y Vibration Sensors, input rated 28V dc max, 20mA; non-incendive with entity parameters of:  $U_i$  (V max) = 28V,  $I_i$  (I max) = 120mA,  $P_i$  = 1W,  $C_i$  = 61 nF,  $L_i$  = 306 uH; when installed per installation Dwg 27536; Temp Code T4 @ Max Ambient 80 Deg C.

Models EXRV64xB0y Vibration Sensors, input rated 28V dc max, 20mA; non-incendive with entity parameters of:  $U_i$  (V max) = 28V,  $I_i$  (I max) = 120mA,  $P_i$  = 1W,  $L_i$  = 121.06 uH,  $C_i$  = 0; when installed per installation Dwg 30538; Temp Code T4 @ Max Ambient 80 Deg C.

Models EXRV64xB1y and EXRV64xB6y Vibration Sensors, input rated 28V dc max, 20mA; non-incendive with entity parameters of:  $U_i$  (V max) = 28V,  $I_i$  (I max) = 120mA,  $P_i$  = 1W,  $C_i$  = 61 nF,  $L_i$  = 426 uH; when installed per installation Dwg 30538; Temp Code T4 @ Max Ambient 80 Deg C.

Notes:

1. Sensor case must be bonded to ground according to Section 18-182 of the CEC, Part 1.
2. The "x" in the model code may be a 0, 1, 5 or 6, which denotes variations in frequency response range of the sensors. The "y" in the model code may be a 0, 1 or 2, which denotes variations in sensor sensitivity.



**Certificate:** 1632187

**Master Contract:** 184981

**Project:** 2655913

**Date Issued:** September 26, 2013

---

Models EX64xA0y Vibration Sensors, input rated 28V dc max, 20mA; non-incendive with entity parameters of:  $U_i$  (V max) = 30V,  $I_i$  (I max) = 100mA,  $P_i$  = 1W,  $L_i$  = 1.06 uH,  $C_i$  = 0; when installed per installation Dwg 27535; Temp Code T4 @ Max Ambient 80 Deg C.

Models 9942VCRT Vibration Sensors, input rated 28V dc max, 20mA; non-incendive with entity parameters of:  $U_i$  (V max) = 30V,  $I_i$  (I max) = 100mA,  $P_i$  = 1W,  $C_i$  = 0,  $L_i$  = 1.06 uH; when installed per installation Dwg 36578; Temp Code T4 @ Max Ambient 80 Deg C.

Models EX64xA1y and EX64xA6y Vibration Sensors, input rated 28V dc max, 20mA; non-incendive with entity parameters of:  $U_i$  (V max) = 30V,  $I_i$  (I max) = 100mA,  $P_i$  = 1W,  $C_i$  = 61 nF,  $L_i$  = 306  $\mu$ H; when installed per installation Dwg 27535; Temp Code T4 @ Max Ambient 80 Deg C.

Models EXTO64xA3y Vibration Sensors, input rated 28V dc max, 20mA; non-incendive with entity parameters of:  $U_i$  (V max) = 28V,  $I_i$  (I max) = 120mA,  $P_i$  = 1W,  $L_i$  = 1.06 uH,  $C_i$  = 0; when installed per installation Dwg 27537; Temp Code T4 @ Max Ambient 80 Deg C.

Models EXTO64xA1y and EXTO64xA6y Vibration Sensors, input rated 28V dc max, 20mA; non-incendive with entity parameters of:  $U_i$  (V max) = 28V,  $I_i$  (I max) = 120mA,  $P_i$  = 1W,  $C_i$  = 61 nF,  $L_i$  = 306  $\mu$ H; when installed per installation Dwg 27537; Temp Code T4 @ Max Ambient 80 Deg C.

Models EXRV64xA0y Vibration Sensors, input rated 28V dc max, 20mA; non-incendive with entity parameters of:  $U_i$  (V max) = 28V,  $I_i$  (I max) = 120mA,  $P_i$  = 1W,  $L_i$  = 121.06 uH  $C_i$  = 0; when installed per installation Dwg 30540; Temp Code T4 @ Max Ambient 80 Deg C.

Models EXRV64xA1y and EXRV64xA6y Vibration Sensors, input rated 28V dc max, 20mA; non-incendive with entity parameters of:  $U_i$  (V max) = 28V,  $I_i$  (I max) = 120mA,  $P_i$  = 1W,  $C_i$  = 61 nF,  $L_i$  = 426  $\mu$ H; when installed per installation Dwg 30540; Temp Code T4 @ Max Ambient 80 Deg C.

Models CS64xB9y Vibration Sensors, input rated 28V dc max, 20mA; non-incendive with entity parameters of:  $U_i$  (V max) = 30V,  $I_i$  (I max) = 100mA,  $P_i$  = 1W,  $C_i$  = 0,  $L_i$  = 1.06 uH; when installed per Dwg 56140; Temp Code T4 @ Max Ambient 80 Deg C.

**Notes:**

1. For Canadian Installations, sensor case must be bonded to ground according to Section 18-182 of the CEC, Part 1.
2. For US Installations, sensor case must be bonded to ground according to Article 501.16 of the NEC.
3. The "x" in the model code may be a 2, 3, 7 or 8, which denotes variations in frequency response range of the sensors. The "y" in the model code may be a 0, 1 or 2, which denotes variations in sensor sensitivity.

**APPLICABLE REQUIREMENTS**

CAN/CSA-C22.2 No. 0-M91 - General Requirements – Canadian Electrical Code, Part II

C22.2 No. 142-M1987(R2009) - Process Control Equipment



**Certificate:** 1632187

**Master Contract:** 184981

**Project:** 2655913

**Date Issued:** September 26, 2013

---

C22.2 No. 213-M1987(R2008) - Non-Incendive Electrical Equipment for Use in Class I, Division 2 Hazardous Locations

UL 916 (4th Ed.) - Energy Management Equipment

UL 1604 (3rd Ed.) - Electrical Equipment for Use in Class I and II, Division 2; Class III Hazardous (Classified) Locations

ANSI/ISA 12.12.01-2000 - Nonincendive Electrical Equipment for Use in Class I and II, Division 2 and Class III, Divisions 1 and 2 Hazardous (Classified) Locations

CAN/CSA-E60079-15:02 - Electrical apparatus for explosive gas atmospheres - Part 15: Type of Protection "n"

ANSI/UL 60079-15:02 - Electrical apparatus for Explosive Gas Atmospheres - Part 15: Type of Protection "n"

**CLASS 2258 02 - PROCESS CONTROL EQUIPMENT - For Hazardous Locations**

**CLASS 2258 82 - PROCESS CONTROL EQUIPMENT – For Hazardous Locations - CERTIFIED TO U.S. STANDARDS**

**Ex nA IICT4:**

**AEx nA IIC T4:**

**Class I, Div. 2, Groups A, B, C, D:**

Models EX64xB7x Vibration Sensors, input rated 28V dc max, 20mA; suitable for use in Class I, Div. 2 or Class I, Zone 2 locations, when installed per installation Dwg 28766; Temp Code T4 @ Max Ambient 80 Deg C.

Models EXTO64xB7x Vibration Sensors, input rated 28V dc max, 20mA; suitable for use in Class I, Div. 2 or Class I, Zone 2 locations, when installed per installation Dwg 28766; Temp Code T4 @ Max Ambient 80 Deg C.

Models EXRV64xB7x Vibration Sensors, input rated 28V dc max, 20mA; suitable for use in Class I, Div. 2 or Class I, Zone 2 locations, when installed per installation Dwg 28766; Temp Code T4 @ Max Ambient 80 Deg C.

Models CS64xB9y Vibration Sensors, input rated 28V dc max, 20mA; suitable for use in Class I, Div. 2 or Class I, Zone 2 locations, when installed per installation Dwg 56140; Temp Code T4 @ Max Ambient 80 Deg C.

Notes:

1. Sensor must be installed in a suitable enclosure, acceptable to the local inspection authority having jurisdiction.



**Certificate:** 1632187

**Master Contract:** 184981

**Project:** 2655913

**Date Issued:** September 26, 2013

---

2. The “x” in the model code may be a 0, 1, 5 or 6, which denotes variations in frequency response range of the sensors. The “y” in the model code may be a 0, 1 or 2, which denotes variations in sensor sensitivity.

### **APPLICABLE REQUIREMENTS**

CAN/CSA-C22.2 No. 0-M91 - General Requirements – Canadian Electrical Code, Part II

C22.2 No. 142-M1987(R2009) - Process Control Equipment

C22.2 No. 213-M1987(R2008) - Non-Incendive Electrical Equipment for Use in Class I, Division 2 Hazardous Locations

UL 916 (4th Ed.) - Energy Management Equipment

UL 1604 (3rd Ed.) - Electrical Equipment for Use in Class I and II, Division 2; Class III Hazardous (Classified) Locations

ANSI/ISA 12.12.01-2000 - Nonincendive Electrical Equipment for Use in Class I and II, Division 2 and Class III, Divisions 1 and 2 Hazardous (Classified) Locations

CAN/CSA-E60079-15:02 - Electrical apparatus for explosive gas atmospheres - Part 15: Type of Protection "n"

ANSI/UL 60079-15:02 - Electrical apparatus for Explosive Gas Atmospheres - Part 15: Type of Protection “n”

### **MARKINGS**

See Descriptive Report for Marking details.