



Model 261A13
3-Component Charge Output Force Sensor
Installation and Operating Manual

**For assistance with the operation of this product,
contact PCB Piezotronics, Inc.**

Toll-free: 800-828-8840
24-hour SensorLine: 716-684-0001
Fax: 716-684-0987
E-mail: info@pcb.com
Web: www.pcb.com



The information contained in this document supersedes all similar information that may be found elsewhere in this manual.

Total Customer Satisfaction – PCB Piezotronics guarantees Total Customer Satisfaction. If, at any time, for any reason, you are not completely satisfied with any PCB product, PCB will repair, replace, or exchange it at no charge. You may also choose to have your purchase price refunded in lieu of the repair, replacement, or exchange of the product.

Service – Due to the sophisticated nature of the sensors and associated instrumentation provided by PCB Piezotronics, user servicing or repair is not recommended and, if attempted, may void the factory warranty. Routine maintenance, such as the cleaning of electrical connectors, housings, and mounting surfaces with solutions and techniques that will not harm the physical material of construction, is acceptable. Caution should be observed to insure that liquids are not permitted to migrate into devices that are not hermetically sealed. Such devices should only be wiped with a dampened cloth and never submerged or have liquids poured upon them.

Repair – In the event that equipment becomes damaged or ceases to operate, arrangements should be made to return the equipment to PCB Piezotronics for repair. User servicing or repair is not recommended and, if attempted, may void the factory warranty.

Calibration – Routine calibration of sensors and associated instrumentation is

recommended as this helps build confidence in measurement accuracy and acquired data. Equipment calibration cycles are typically established by the users own quality regimen. When in doubt about a calibration cycle, a good “rule of thumb” is to recalibrate on an annual basis. It is also good practice to recalibrate after exposure to any severe temperature extreme, shock, load, or other environmental influence, or prior to any critical test.

PCB Piezotronics maintains an ISO-9001 certified metrology laboratory and offers calibration services, which are accredited by A2LA to ISO/IEC 17025, with full traceability to N.I.S.T. In addition to the normally supplied calibration, special testing is also available, such as: sensitivity at elevated or cryogenic temperatures, phase response, extended high or low frequency response, extended range, leak testing, hydrostatic pressure testing, and others. For information on standard recalibration services or special testing, contact your local PCB Piezotronics distributor, sales representative, or factory customer service representative.

Returning Equipment – *Following these procedures will insure that your returned materials are handled in the most expedient manner.* Before returning any equipment to PCB Piezotronics, contact your local distributor, sales representative, or factory customer service representative to obtain a Return

Materials Authorization (RMA) Number. This RMA number should be clearly marked on the outside of all package(s) and on the packing list(s) accompanying the shipment. A detailed account of the nature of the problem(s) being experienced with the equipment should also be included inside the package(s) containing any returned materials.

A Purchase Order, included with the returned materials, will expedite the turn-around of serviced equipment. It is recommended to include authorization on the Purchase Order for PCB to proceed with any repairs, as long as they do not exceed 50% of the replacement cost of the returned item(s). PCB will provide a price quotation or replacement recommendation for any item whose repair costs would exceed 50% of replacement cost, or any item that is not economically feasible to repair. For routine calibration services, the Purchase Order should include authorization to proceed and return at current pricing, which can be obtained from a factory customer service representative.

Warranty – All equipment and repair services provided by PCB Piezotronics, Inc. are covered by a limited warranty against defective material and workmanship for a period of one year from date of original purchase. Contact

PCB for a complete statement of our warranty. Expendable items, such as batteries and mounting hardware, are not covered by warranty. Mechanical damage to equipment due to improper use is not covered by warranty. Electronic circuitry failure caused by the introduction of unregulated or improper excitation power or electrostatic discharge is not covered by warranty.

Contact Information – International customers should direct all inquiries to their local distributor or sales office. A complete list of distributors and offices can be found at www.pcb.com. Customers within the United States may contact their local sales representative or a factory customer service representative. A complete list of sales representatives can be found at www.pcb.com. Toll-free telephone numbers for a factory customer service representative, in the division responsible for this product, can be found on the title page at the front of this manual. Our ship to address and general contact numbers are:

PCB Piezotronics, Inc.
3425 Walden Ave.
Depew, NY 14043 USA
Toll-free: (800) 828-8840
24-hour SensorLineSM: (716) 684-0001
Website: www.pcb.com
E-mail: info@pcb.com

Table of Contents

<u>Section</u>		<u>Page</u>
1.0	Introduction	2
2.0	Description	2
3.0	Installation	2
4.0	Operation	3
5.0	Polarity	3
6.0	Low Frequency Monitoring	4
7.0	Discharge Time Constant	4
8.0	Calibration	5
9.0	Troubleshooting	5
10.0	Maintenance	6

<u>Figure</u>		<u>Page</u>
1	3-Component Force Link Axis Definition	2
2	Charge Mode 3-Component Force Link	2
3	Cable Strain Relief	3
4	Characteristic Discharge Time Constant Curve	4
5	Step Function Response	4

MANUAL NUMBER: 29014
MANUAL REVISION: NR
ECO NUMBER:

1.0 INTRODUCTION

PCB Piezotronics 3-component force link sensors are designed to simultaneously measure dynamic and quasi-static force measurements in three orthogonal directions; F_x , F_y , and F_z . (Figure 1) The sensors utilize an array of precision aligned, quartz sensing crystals stacked in a preloaded arrangement.

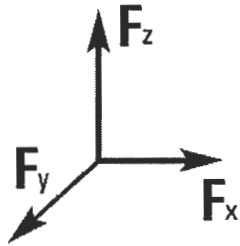

Figure 1 - 3-Component Force Link Axis Definition

2.0 DESCRIPTION

A link consists of a standard PCB 3-component force sensor, preloaded between two precision ground plates. (Figure 2) The plates are internally threaded to facilitate fixturing for both tensile and compressive force measurements. External preloads are not required with these sensors, as they are internally preloaded during manufacture.

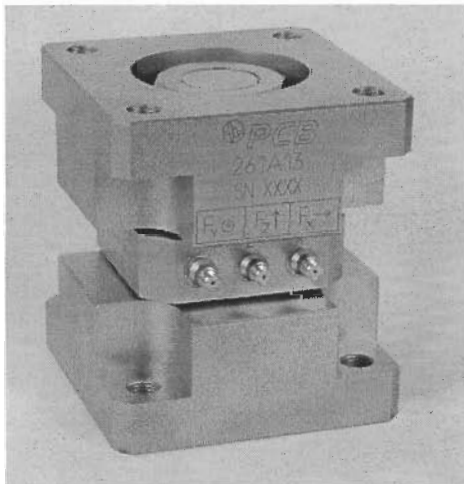

Figure 2 - Charge-Mode 3-Component Force Link

Caution: Loosening or tightening of the hex nuts will change the internal preload of the sensor. At this point, the sensitivity provided on the calibration certificate will no longer represent that of the sensor.

If this should occur, refer to the service and repair document for proper information.

Measurements along the z-axis are proportional to applied compression, tension, and impact forces. Measurements along the x- and y-axis are proportional to shear forces imposed upon the sensor.

Charge output sensors do not contain built-in signal conditioning circuitry. They require external signal conditioning from in-line charge converters or laboratory-style charge amplifiers and use special, low noise cables for signal transmission. The sensor is capable of high temperature operation. The system output signal can be ranged by the charge amplifier to suit this particular application.

If questions arise regarding the operation or characteristics of the force sensor products as outlined in this manual, feel free to contact an experienced applications engineer from the Force/Torque Division of PCB toll-free 888-684-0004.

3.0 INSTALLATION

Refer to the installation/outline drawing supplied with this manual for specific outline dimensions and installation details for your particular model. The specification is also included to provide details of the sensor's characteristic properties.

The condition of the mating surfaces can adversely affect the sensitivity of the sensor. It is essential that all surfaces be clean, rigid and perfectly flat to avoid erroneous data. A good mating surface may be obtained by lapping, turning, spot-facing, or surface grinding. Surface flatness should be held to within 0.001 (TIR) over the entire mating surface. The protective cap should remain on the connectors during installation to prevent contamination or damage.

A light coating of silicon grease (DC-4 or equivalent) on the mating surface enhances the coupling between the mounting base and mounting surface and provides the best high-frequency response.

Caution!

**High Insulation Resistance – Do not touch connector.
Keep clean and dry.**

Connect one end of a low noise interconnect cable to the sensor connector and the other end to the XDCR jack on the signal conditioner. Make sure to tighten the cable connector to the sensor. **DO NOT** spin the sensor onto the cable, as this fatigues the cable's center pin, resulting in a shorted signal and a damaged cable.

For installation in dirty, humid, or rugged environments, it is suggested that the connection be shielded against dust or moisture with shrink tubing or other protective material. Strain relieving the cable/sensor connection can also prolong cable life. Mounting cables to a test structure with tape, clamps, or adhesives minimizes cable whip.

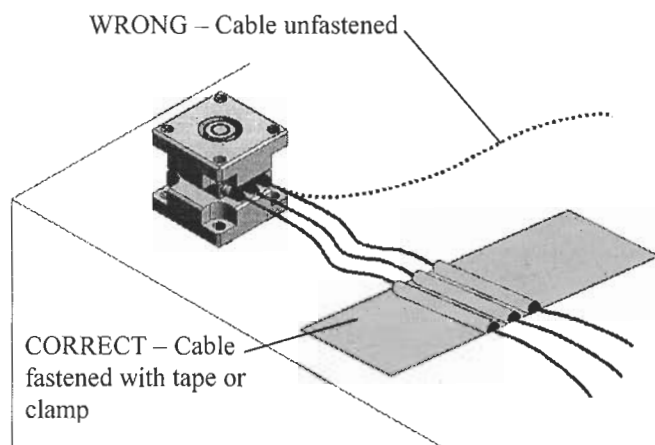

Figure 3 - Cable Strain Relief

4.0 OPERATION

Caution: Please read all instructions before attempting to operate this product.

Charge mode sensors require an external charge amplifier for impedance conversion. The charge amplifier should be placed as close to the sensor as possible to avoid contamination and minimize triboelectric (cable) noise. The rubbing of the strands within the cable that creates a static charge causes this

triboelectric noise. It is important to keep the cable well strain relieved during testing to help reduce noise.

Each cable also has a capacitance-per-length specification, measured in Pico farads. This additional capacitance must be taken into account when determining total system capacitance. It is important to keep the low-noise cable length between the sensor and charge amplifier, or charge converter, as short as possible.

During applications in which the charge amplifier cannot be placed near the sensor, an external charge converter or source follower may be substituted. PCB Series 402 (non-signal inverting) and Series 422 (signal inverting) miniature charge amplifiers can be installed in-line with the charge sensor. These charge converters convert the sensor's high impedance charge signal to a low-impedance voltage that is transmitted across long cables to the signal conditioner and readout. The small size of these converters allows signal conversion in remote or restricted areas.

Operation requires the connection of the force sensor first to a charge amplifier or charge converter. PCB Series 003 Low-Noise Cable should be incorporated at this location. Tighten the coaxial cable to the sensor by hand to ensure good electrical contact. **DO NOT** spin the sensor onto the mating cable connector, as this fatigues the cable's center pin, resulting in a shorted signal and a damaged cable. If operating directly to a charge amplifier, the signal may then be routed from a charge amplifier to the readout devices. If an in-line charge converter is used (Series 402 or 422), the signal may be routed from the converter to an ICP® constant-current signal conditioner, such as Series 440, 480, 482, or 484. From the signal conditioner, readout instruments may be directly connected. It is recommended to use a source follower as close as possible to the charge output sensor. Driving long cables in a charge mode system is not suggested due to the induced noise.

5.0 POLARITY

Compressive forces upon a charge mode force sensor produce a negative output. Tensile forces produce a positive output. Most charge amplifiers invert the signal from piezoelectric sensors. Sensors with reversed polarity are available upon request.

6.0 LOW-FREQUENCY MONITORING

Low frequency response of high-impedance systems is determined by the electrical characteristics of the charge amplifier. Consult the charge amplifier specifications for these characteristics.

PCB charge amplifiers have settings for short, medium, and long time constants. The short time constant is provided for use during repetitive, or transient, dynamic applications. The medium time constant is designed for slightly longer applications and some calibrations. The long time constant is provided for even longer quasi-static applications, as well as calibrations. The low frequency response of the application depends on the input resistance of the sensing system, namely the sensor cable, amplifier and readout device.

7.0 DISCHARGE TIME CONSTANT

The discharge time constant represents the decay rate of an input signal. One DTC represents the amount of time taken for the signal to decay to 37% of the initial peak value. As illustrated in **Figure 3**, this is an exponential decay. Approximately five DTC intervals are needed for a peak signal to naturally decay back to zero.

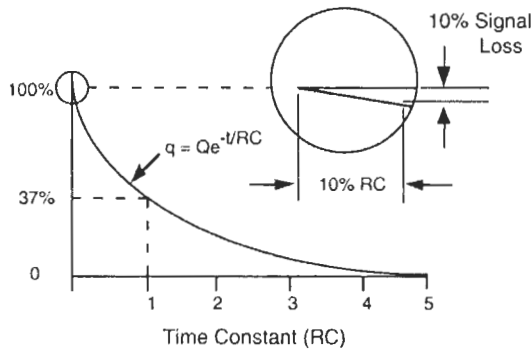

Figure 4 - Characteristic Discharge Time Constant Curve

The rule of thumb for signal discharge, as outlined in **Figure 3**, is this: for the first 10% of the DTC, the signal lost is approximately proportional to the time elapsed.

Time Constant Determination in Charge Mode Systems

Discharge Time Constant (DTC) of a charge mode system is determined by multiplying the desired operating range setting of the charge amplifier by setting of the amplifier DTC switch, located on the charge amplifier (refer to specific charge amplifier for the DTC

settings). Many PCB charge amplifiers have short, medium, and long DTC settings. See the operating manual of the specific charge amplifier in question for DTC position factors.

It is possible to measure quasi-static events with piezoelectric sensors. Over the first 10% of the DTC, signal decay and accuracy represent a one-to-one relationship. Over 2% of the DTC, a 2% signal loss has occurred. Over 7%, a 7% signal loss has occurred, and so on. For 1% measurement accuracy, it is recommended that the reading be taken within the first 1% of the DTC. (**Figure 4**) If it is possible to avoid AC coupling somewhere in the sensing system, try to keep the coupling time constant at least an order of magnitude longer than the DTC of the force sensor. This avoids compromising the sensor DTC.

Step Function Response

For example, a sensor with a 500-second DTC loses approximately 1% of its output level the first five seconds (1% of 500) after the application of a steady state force within the measuring range. In this case, the output reading must be taken within five seconds of the force application for 1% accuracy. If it is impossible to avoid AC coupling somewhere in the sensing system, try to keep the coupling DTC at least an order of magnitude longer than the DTC of the force sensor. This avoids compromising the sensor DTC.

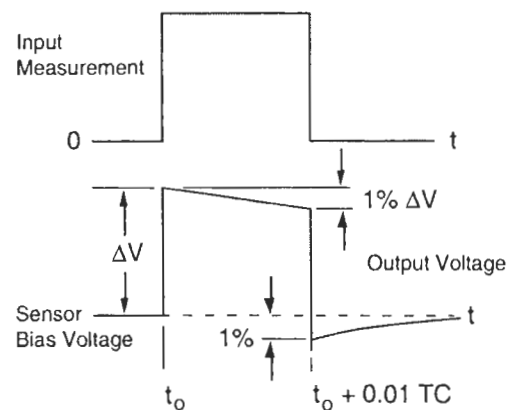

Figure 5 - Step Function Response

8.0 CALIBRATION

A NIST (National Institute of Standards and Technology) traceable calibration graph is supplied with each force sensor certifying its voltage sensitivity (mV/lb). Calibration procedures follow accepted guidelines as recommended by ANSI (American National Standards Institute), ISA (Instrument Society of America), and ISO (International Organization for Standardization). These standards provide the establishment and management of complete calibration systems, thus controlling the accuracy of a sensor's specifications by controlling measuring and test equipment accuracy. PCB is A2LA accredited for technical competence in the field of calibration, meeting the requirements of ISO/IEC 17025-1999 and ANSI/NCSL 2540-1-1994.

9.0 TROUBLESHOOTING

<u>Problem:</u>	<u>Possible Cause(s):</u>	<u>Solution:</u>
No Output	Faulty or no cable connection Improper time constant (TC) switch setting Low sensor capacitance Faulty charge amp Low sensor insulation (less than 1×10^{12})	Properly attach or replace cable Ensure switch is set properly (SHORT/ MED/ LONG) Call factory for service Call factory for service Call factory for service
Intermittent Output	Faulty cable connection Improper charge amp setting Intermittent sensor	Properly attach or replace cable Set charge amp to proper setting Call factory for service
Output Drift	Faulty cable Rapid Temperature Change Low charge amp insulation Low sensor insulation Faulty sensor	Replace cable Allow sensor to adapt to environment Call factory for service Call factory for service Call factory for service
Improper Sensor Sensitivity	Improper XDCR sensitivity dial setting Faulty sensor	Ensure dial is adjusted and locked into proper setting Call factory for service

10.0 MAINTENANCE

The sensor connector must be kept clean, especially if it is operating in a dusty and/or wet environment. Because the force sensor is of welded construction, it should be returned to the factory for servicing in the event of serious malfunction.

Observe the following precautions in using the sensor:

- Do not exceed the maximum load levels for the force sensor (see specification sheet).
- Do not subject the sensor to temperatures exceeding that of the specification, normally 350°F (177°C).
- Do not apply voltage or current to the sensor.
- When mounting the force sensor, observe installation procedures detailed in Section 3.0 and as outlined on the specific sensor installation/outline drawing to avoid overtorquing when mounting.
- Avoid metal-to-metal impacts during applications, which can produce high frequency ringing. Electrical low-pass filtering or a damping material can help reduce such effects.
- Do not spin the sensor onto the cable. This may fatigue the cable center pin, causing cable damage. Always insert the cable pin into the sensor and tighten the knurled cable nut to the sensor.

Model Number 261A13	3-COMPONENT CHARGE OUTPUT FORCE SENSOR			Revision: A ECN #: 33704										
Performance Sensitivity(± 15 %)(z axis) Sensitivity(± 15 %)(x or y axis) Measurement Range(z axis) Measurement Range(x or y axis) Maximum Force(z axis) Maximum Force(x or y axis) Maximum Moment(z axis) Maximum Moment(x or y axis) Upper Frequency Limit Non-Linearity Cross Talk(between x and y axis) Cross Talk(between (x or y axis) and z axis)	ENGLISH 15 pC/lb 32 pC/lb 10,000 lb 4000 lb 11,000 lb 4400 lb 240 ft-lb 325 ft-lb 10 kHz ≤ 1 % FS ± 3 % ± 5 %	SI 3.37 pC/N 7.19 pC/N 44.48 kN 17.7 kN 48.93 kN 19.57 kN 325.4 N-m 440.7 N-m 10 kHz ≤ 1 % FS ± 3 % ± 5 %	[2] [2] [3]	<p style="text-align: center;">OPTIONAL VERSIONS</p> <p>Optional versions have identical specifications and accessories as listed for the standard model except where noted below. More than one option may be used.</p> <p>M - Metric Mount Supplied Accessory : Model M081A71 Mounting Stud (1)</p> <p>W - Water Resistant Cable Electrical Connection Position</p> <p style="text-align: right;">Side Side</p>										
Environmental Temperature Range	-100 to +350 °F	-73 to +177 °C		<p>NOTES: [1] Typical. [2] Sensitivites are for listed preload. Sensitivites may vary ±5% depending on preload used. [3] Zero-based, least-squares, straight line method.</p>										
Electrical Capacitance(all channels) Insulation Resistance(all channels) Output Polarity(in direction of markings)	70 pF ≥ 10 ¹² ohm Negative	70 pF ≥ 10 ¹² ohm Negative	[1]											
Physical														
Stiffness(z axis)	40 lb/μin	7 kN/μm	[1]											
Stiffness(x or y axis)	15 lb/μin	2.6 kN/μm	[1]											
Weight	96.25 oz	2994 gm												
Housing Material	Stainless Steel	Stainless Steel												
Sealing	Hermetic	Hermetic												
Electrical Connector(Quantity, 3)	10-32 Coaxial Jack	10-32 Coaxial Jack												
Electrical Connection Position	Side	Side												
<p><i>All specifications are at room temperature unless otherwise specified. In the interest of constant product improvement, we reserve the right to change specifications without notice.</i></p>														
<p>ICP® is a registered trademark of PCB Group, Inc.</p>														
<table border="1" style="width: 100%; border-collapse: collapse;"> <tr> <td style="width: 15%;">Entered: DMW</td> <td style="width: 15%;">Engineer: MJK</td> <td style="width: 15%;">Sales: KWW</td> <td style="width: 15%;">Approved: EB</td> <td style="width: 40%;">Spec Number:</td> </tr> <tr> <td>Date: 8/17/10</td> <td>Date: 8/17/10</td> <td>Date: 8/17/10</td> <td>Date: 8/17/10</td> <td style="text-align: center;">29018</td> </tr> </table> <p style="text-align: center;">PCB PIEZOTRONICS FORCE / TORQUE DIVISION 3425 Walden Avenue, Depew, NY 14043</p> <p style="text-align: right;">Phone: 716-684-0001 Fax: 716-684-8877 E-Mail: force@pcb.com</p>					Entered: DMW	Engineer: MJK	Sales: KWW	Approved: EB	Spec Number:	Date: 8/17/10	Date: 8/17/10	Date: 8/17/10	Date: 8/17/10	29018
Entered: DMW	Engineer: MJK	Sales: KWW	Approved: EB	Spec Number:										
Date: 8/17/10	Date: 8/17/10	Date: 8/17/10	Date: 8/17/10	29018										

PCB Piezotronics Inc. claims proprietary rights in the information disclosed hereon. Neither it nor any reproduction thereof will be disclosed to others without the written consent of PCB Piezotronics Inc.

35858

REVISIONS

REV	DESCRIPTION	ECN	APP'D
NR	RELEASED TO DRAFTING		ECB 11/06
A	CHANGE 3/8 TO 7/8	29828	ECB 12/08

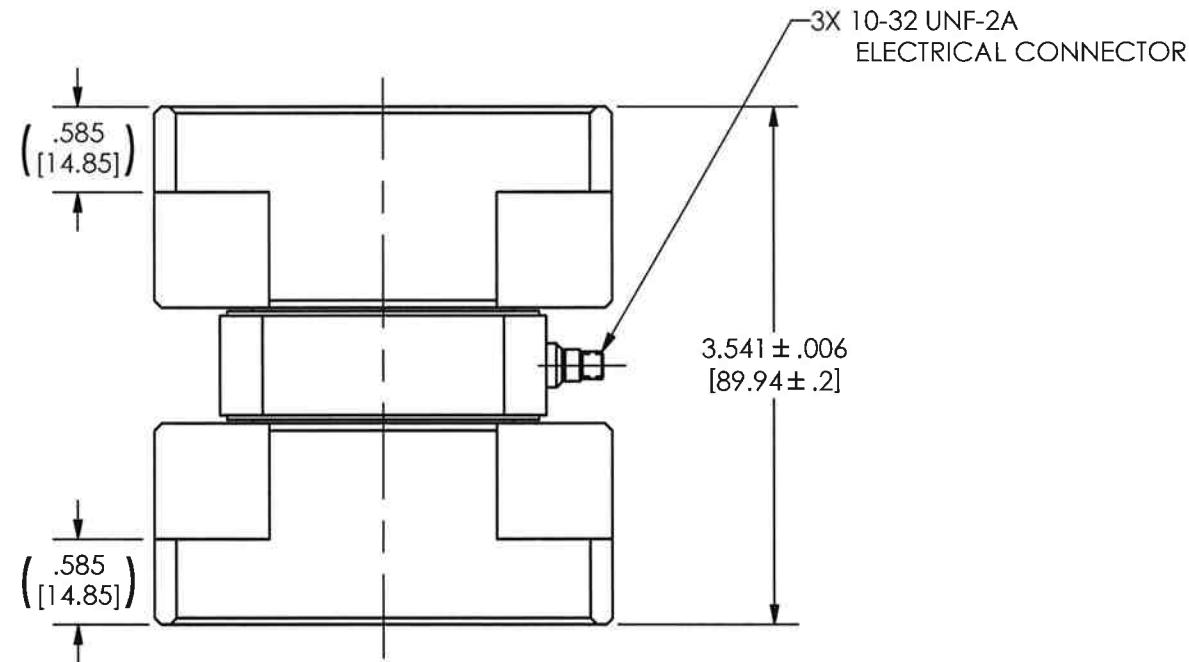
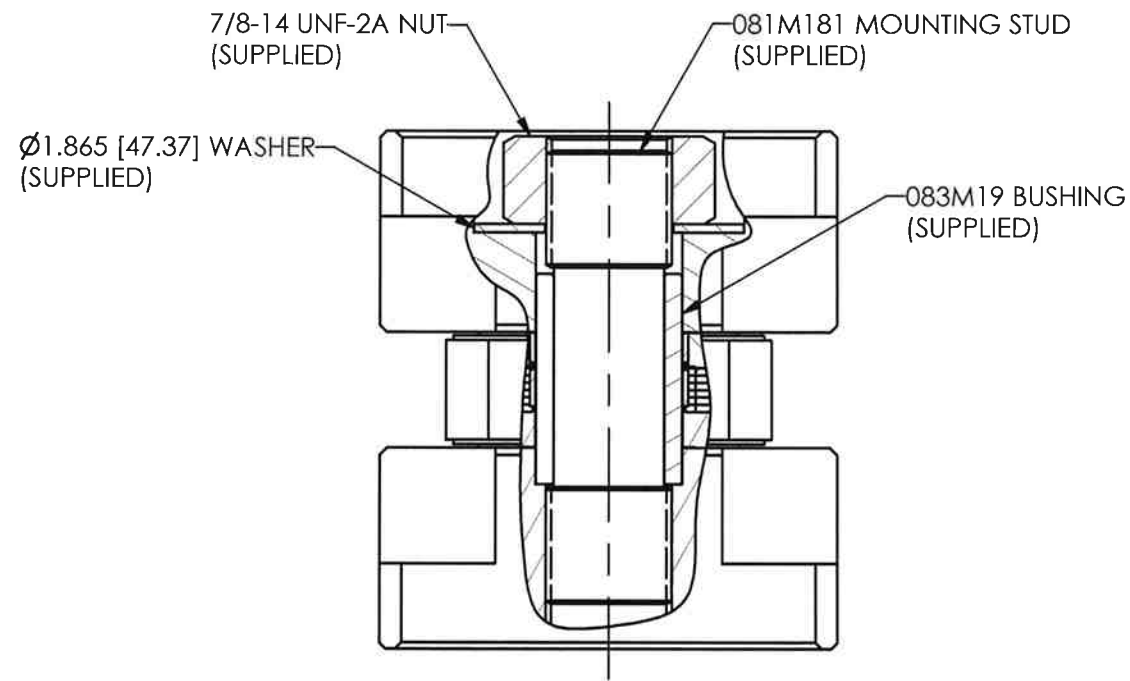
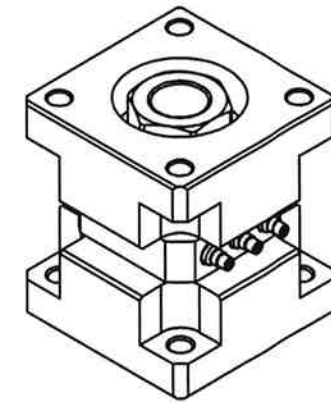
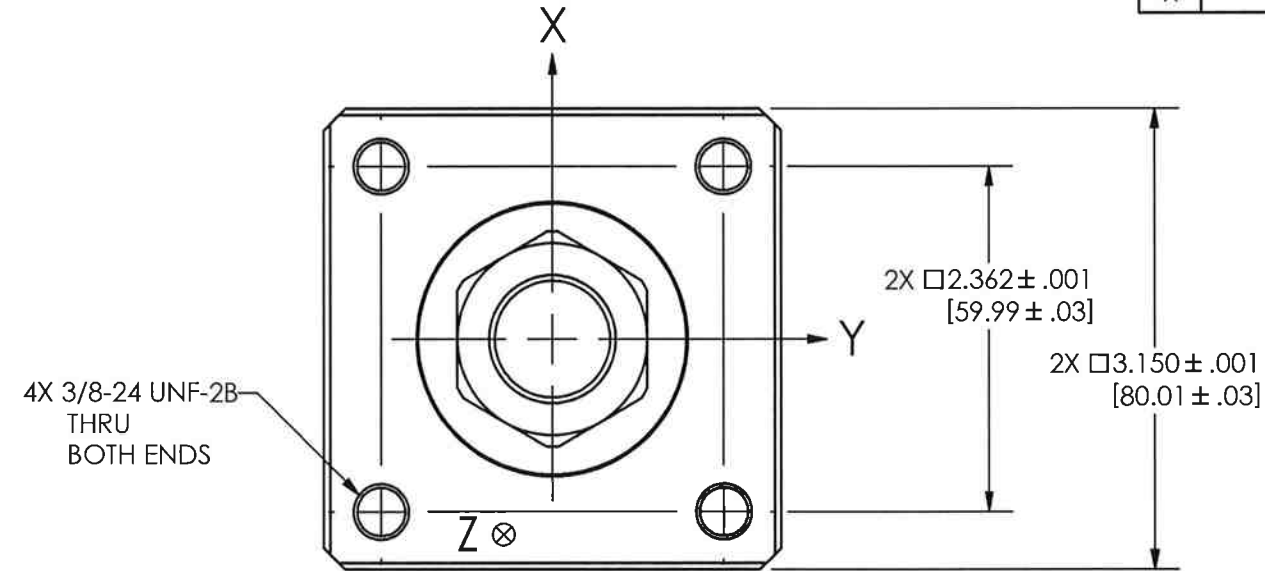

UNLESS OTHERWISE SPECIFIED TOLERANCES ARE:		DRAWN	ECB	12/29/08	MFG	JAM	12/29/08	 PCB PIEZOTRONICS [™] 3425 WALDEN AVE. DEPEW, NY 14043 (716) 684-0001 E-MAIL: sales@pcb.com	
DIMENSIONS IN INCHES		CHK'D	ECB	12/29/08	ENGR	BAM	12/29/08		
DECIMALS XX ± .03 XXX ± .010		APP'D	EB	12/29/08	SALES	RWM	12/29/08		
ANGLES ± 2 DEGREES		TITLE							
DIMENSIONS IN MILLIMETERS [IN BRACKETS]		OUTLINE DRAWING MODEL 261A13 TRIAXIAL FORCE SENSOR						CODE IDENT. NO. 52681	DWG. NO. 35858
DECIMALS X ± 0.8 XX ± 0.25								SCALE: .75 X	SHEET 1 OF 1
ANGLES ± 2 DEGREES									
FILLETS AND RADII .003 - .005									
FILLETS AND RADII [0.07 - 0.13]									