



**Model 103B12**  
**PRESSURE SENSOR, ICP®, ACOUSTIC**  
**Installation and Operating Manual**

**For assistance with the operation of this product,  
contact PCB Piezotronics, Inc.**

**Toll-free: 800-828-8840**  
**24-hour SensorLine: 716-684-0001**  
**Fax: 716-684-0987**  
**E-mail: [info@pcb.com](mailto:info@pcb.com)**  
**Web: [www.pcb.com](http://www.pcb.com)**



**The information contained in this document supersedes all similar information that may be found elsewhere in this manual.**

**Total Customer Satisfaction** – PCB Piezotronics guarantees Total Customer Satisfaction. If, at any time, for any reason, you are not completely satisfied with any PCB product, PCB will repair, replace, or exchange it at no charge. You may also choose to have your purchase price refunded in lieu of the repair, replacement, or exchange of the product.

**Service** – Due to the sophisticated nature of the sensors and associated instrumentation provided by PCB Piezotronics, user servicing or repair is not recommended and, if attempted, may void the factory warranty. Routine maintenance, such as the cleaning of electrical connectors, housings, and mounting surfaces with solutions and techniques that will not harm the physical material of construction, is acceptable. Caution should be observed to insure that liquids are not permitted to migrate into devices that are not hermetically sealed. Such devices should only be wiped with a dampened cloth and never submerged or have liquids poured upon them.

**Repair** – In the event that equipment becomes damaged or ceases to operate, arrangements should be made to return the equipment to PCB Piezotronics for repair. User servicing or repair is not recommended and, if attempted, may void the factory warranty.

**Calibration** – Routine calibration of sensors and associated instrumentation is

recommended as this helps build confidence in measurement accuracy and acquired data. Equipment calibration cycles are typically established by the users own quality regimen. When in doubt about a calibration cycle, a good “rule of thumb” is to recalibrate on an annual basis. It is also good practice to recalibrate after exposure to any severe temperature extreme, shock, load, or other environmental influence, or prior to any critical test.

PCB Piezotronics maintains an ISO-9001 certified metrology laboratory and offers calibration services, which are accredited by A2LA to ISO/IEC 17025, with full traceability to N.I.S.T. In addition to the normally supplied calibration, special testing is also available, such as: sensitivity at elevated or cryogenic temperatures, phase response, extended high or low frequency response, extended range, leak testing, hydrostatic pressure testing, and others. For information on standard recalibration services or special testing, contact your local PCB Piezotronics distributor, sales representative, or factory customer service representative.

**Returning Equipment** – *Following these procedures will insure that your returned materials are handled in the most expedient manner.* Before returning any equipment to PCB Piezotronics, contact your local distributor, sales representative, or factory customer service representative to obtain a Return

Materials Authorization (RMA) Number. This RMA number should be clearly marked on the outside of all package(s) and on the packing list(s) accompanying the shipment. A detailed account of the nature of the problem(s) being experienced with the equipment should also be included inside the package(s) containing any returned materials.

A Purchase Order, included with the returned materials, will expedite the turn-around of serviced equipment. It is recommended to include authorization on the Purchase Order for PCB to proceed with any repairs, as long as they do not exceed 50% of the replacement cost of the returned item(s). PCB will provide a price quotation or replacement recommendation for any item whose repair costs would exceed 50% of replacement cost, or any item that is not economically feasible to repair. For routine calibration services, the Purchase Order should include authorization to proceed and return at current pricing, which can be obtained from a factory customer service representative.

**Warranty** – All equipment and repair services provided by PCB Piezotronics, Inc. are covered by a limited warranty against defective material and workmanship for a period of one year from date of original purchase. Contact

PCB for a complete statement of our warranty. Expendable items, such as batteries and mounting hardware, are not covered by warranty. Mechanical damage to equipment due to improper use is not covered by warranty. Electronic circuitry failure caused by the introduction of unregulated or improper excitation power or electrostatic discharge is not covered by warranty.

**Contact Information** – International customers should direct all inquiries to their local distributor or sales office. A complete list of distributors and offices can be found at [www.pcb.com](http://www.pcb.com). Customers within the United States may contact their local sales representative or a factory customer service representative. A complete list of sales representatives can be found at [www.pcb.com](http://www.pcb.com). Toll-free telephone numbers for a factory customer service representative, in the division responsible for this product, can be found on the title page at the front of this manual. Our ship to address and general contact numbers are:

PCB Piezotronics, Inc.  
3425 Walden Ave.  
Depew, NY 14043 USA  
Toll-free: (800) 828-8840  
24-hour SensorLine<sup>SM</sup>: (716) 684-0001  
Website: [www.pcb.com](http://www.pcb.com)  
E-mail: [info@pcb.com](mailto:info@pcb.com)

OPERATION MANUAL FOR  
MICROPHONE  
Series 103A

## 1.0 DESCRIPTION

The Series 103A microphones are high-sensitivity pressure sensors featuring miniature size, built-in solid state electronics and acceleration compensation.

The Model 103A (see installation drawing) has pigtail leads extending radially from the side of the unit and has a nominal sensitivity of 1500 mV/psi.

The Model 103A11 is similar in appearance and in mode of electrical connection, but differs from the Model 103A in that the sensitivity is nominally 500 mV/psi.

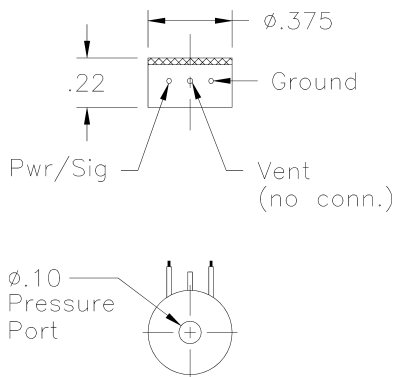

### Models 103A and 103A11: ICP® Sound Pressure Sensors

The Model 103A02 is similar physically to the 103A and has similar sensitivity (1500 mV/psi), but the electrical connection is made through a top mounted 10-32 coaxial connector.

The Model 103A12 also has the top connector like the 103A02 but the sensitivity is 500 mV/psi.

These units are ideal for wind tunnel testing of models because of the small size and high sensitivity.

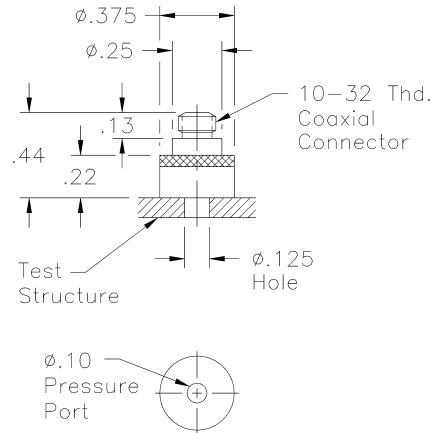

### Models 103A02 and 103A12: ICP® Sound Pressure Sensors

## 2.0 DESCRIPTION

(Refer to installation drawing no. 103-1010-90 included as part of this manual.)

The 103A Series Sensors utilize a bimorph bender crystal cantilevered from the side wall and attached to the center of a thin recessed invar diaphragm. Pressure acting on the surface of the diaphragm results in a net force which strains (or deflects) the diaphragm in proportion to the applied pressure. The diaphragm bends the crystal creating an output voltage which is also proportional to applied pressure.

This voltage is fed to the gate of a miniature MOSFET source follower amplifier which reduces the output impedance to less than 100 Ohms allowing the driving of long cables and permitting operating directly into most readout instruments.

Refer to Bulletin G-0001B, "General Guide to ICP® Instrumentation" for a detailed description of the built-in amplifier concept.

Models 103A, A02, A11, and A12 have output signals superimposed upon a +4 V (approx.) bias level at the amplifier output. All PCB signal conditioners are designed to eliminate this bias voltage while supplying power to the internal amplifier.

# OPERATION MANUAL FOR MICROPHONE Series 103A

The result is a two-wire system, precluding the need for multi-conductor cabling.

A second diaphragm, located behind the pressure diaphragm and attached to another bimorph bender crystal acting in opposition to the pressure crystal, provides acceleration compensation to the Series 103A Sensors.

### 3.0 INSTALLATION

As shown in installation drawing 103-1010-90, the Series 103A Microphones may be properly mounted in several ways, the exact method chosen being a function of the space available along with other use dictated parameters.

The simplest method of mounting, and also the one that utilizes the least volume, is the adhesive method. The microphone is simply bonded directly to the mounting surface with an (at least) .10" diameter hole through the surface to feed the pressure signal to the diaphragm.

Many different types of adhesives may be used to bond the 103A in this manner. The important point being to apply the adhesive very sparingly so that removal does not damage the sensor.

The 103A may also be mounted using the Model 061A04 Servo clamps if space is available.

The Model 060A11 Clamp Nut may only be used with the top connector Models 103A02 and 103A12 since the radial wire leads of the Model 103A and 103A11 would interfere with the clamp nut. The installation drawing gives detailed instructions on preparation of the port for this type of installation.

### 3.1 ELECTRICAL

For the Models 103A and 103A11 (pigtail models), connect the center conductor from the "Xducer" output of any ICP® power unit to the white (Pwr/Sig) lead and connect the outer shell of the "Xducer" connector to the black (ground) lead. The black lead is electrically connected to the outer case. (See figure below.)

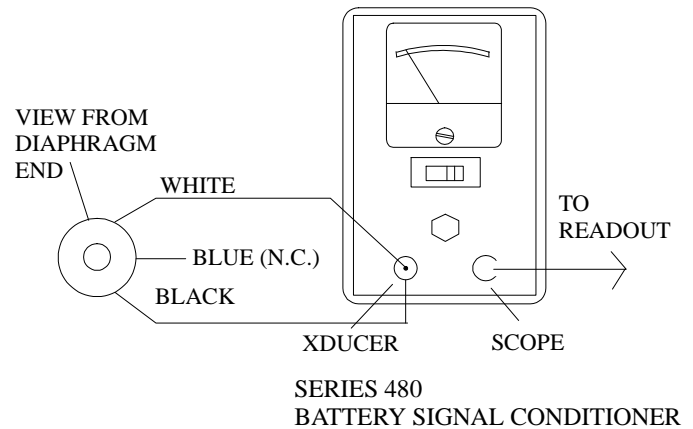

#### Models 103A & All: Electrical Connection

NOTE: No electrical connection is made to the blue (vent) lead. This lead serves to vent internal pressure within the sensor when the 103A and 103A11 are used in evacuated chambers. The internal pressure bleeds out slowly around the wires of this lead. This lead may be cut off flush with body if the sensor will never be used in this manner.

To make the electrical connection to the Models 103A02 and 103A12 (top connector models), simply connect the "Xducer" output of the power unit to the 10-32 coaxial connector using a PCB Model 002C Series coaxial cable.

The output signal is taken from the power unit connector labeled "Scope" or "Output". (See figure below.)

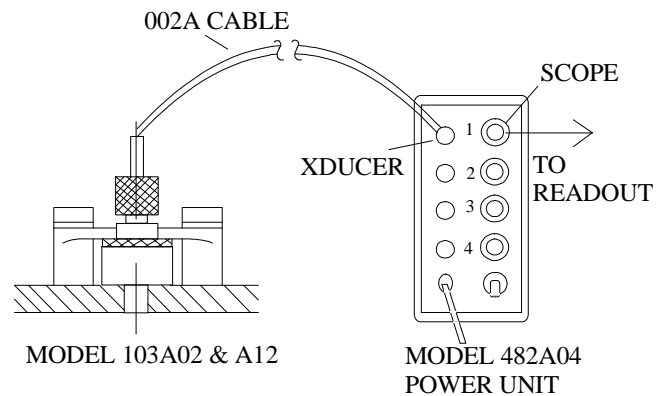

#### Models 103A02 & A12: Electrical Connection

OPERATION MANUAL FOR  
MICROPHONE  
Series 103A

Refer to Guide G-0001B for tips on power and signal utilization.

NOTE: The internal low-noise amplifier in the Model 103A, A02, A11 and A12 differ from the standard ICP<sup>®</sup> amplifiers described in Guide G-0001B in that the turn-on (or bias) voltage is nominally +4 volts.

Proper turn-on for Models 103A02, A11 and A1 2 will not give center scale reading on the fault monitor meters found on most PCB signal conditioners but will show a reading of approximately 20% of F.S. on these meters. This puts it at the lower limit of the green (or normal) area of the meters. This is normal and in no way indicates faulty operation.

#### 4.0 OUTPUT SIGNAL

The output signal from the 103A Series is a voltage proportional to input pressure. The polarity is positive-going for increasing input pressure.

The signal is of high enough level and low enough output impedance to be fed directly into most oscilloscopes, tape recorders, strip chart recorders, A to D converters, etc.

Consult the factory for information regarding galvo driving since special amplifiers are needed to drive most high-current galvanometers.

Low-frequency response is limited by sensor discharge TC (given in the specification sheet) and by coupling time constants throughout the system. To take full advantage of the TC of the sensor, make sure that coupling TC's from power unit to readout are at least an order of magnitude longer than the discharge TC or use a direct-coupled signal conditioner such as the Model 484B. Consult factory for details.

#### 5.0 CALIBRATION

The 103A Series Sensors must be dynamically calibrated using a known step function or pulse, or with a microphone calibrator.

At PCB, the units are subjected to various calibrated steps of pneumatic pressure to obtain a linearity curve over the full range of the instruments.

#### 6.0 MAINTENANCE AND REPAIR

The small size and sealed construction of the Series 103A precludes field maintenance and repair.

Should the time constant degrade or an abnormality appear in the normal bias voltage, bake the unit out in a +250° F oven for 1 to 2 hours, then re-test.

If this is not effective or if other problems should occur, contact the factory for assistance in tracing the problem or for instructions on returning the unit for repair.

#### 7.0 PRECAUTIONS

- 1.) Do not apply voltage to the unit without a current-limiting device in the line such as incorporated in all PCB signal conditioners, (20 mA maximum) to do so will destroy the internal amplifier.
- 2.) Do not subject these units to temperatures higher than 250° F.
- 3.) Do not attempt to disassemble these units as to do so voids the warranty.
- 4.) Use caution when removing units that have been mounted with epoxies or other strong adhesives. Excessive squeezing or torquing may damage the units and/or cause a calibration shift.
- 5.) In vibratory environments, secure cables and leads to surrounding structures to avoid lead or cable damage.
- 6.) Do not over torque when using the Servo clamps or the clamp nut since this could damage the units.
- 7.) Do not overpressure (see specs for maximum pressure), to do so may change the calibration.

Model Number  
103B12

# ACOUSTIC ICP® PRESSURE SENSOR

Revision: A  
ECN #: 20134

	ENGLISH	SI	
<b>Performance</b>			
Measurement Range (± 5 V output)	10 psi	190.7 dB	
Useful Overrange (± 10 V output)	20 psi	196.7 dB	[1]
Sensitivity (± 15 %)	500 mV/psi	72.5 mV/kPa	
Maximum Pressure	250 psi	1724 kPa	
Resolution	0.06 mpsi	86.3 dB	
Resonant Frequency	≥ 13 kHz	≥ 13 kHz	
Rise Time	≤ 25 μ sec	≤ 25 μ sec	
Low Frequency Response (-5 %)	5 Hz	5 Hz	
Non-Linearity	≤ 2.0 % FS	≤ 2.0 % FS	[2]
<b>Environmental</b>			
Acceleration Sensitivity	≤ 0.0005 psi/g	≤ 0.0035 kPa/(m/s <sup>2</sup> )	
Temperature Range (Operating)	-100 to 250 °F	-73 to 121 °C	
Temperature Coefficient of Sensitivity	≤ 0.2 %/°F	≤ 0.36 %/°C	
Maximum Flash Temperature	1000 °F	538 °C	
Maximum Shock	1000 g pk	9807 m/s <sup>2</sup> pk	
<b>Electrical</b>			
Output Polarity (Positive Pressure)	Positive	Positive	
Discharge Time Constant (at room temp)	≥ 0.1 sec	≥ 0.1 sec	
Excitation Voltage	20 to 30 VDC	20 to 30 VDC	
Constant Current Excitation	2 to 20 mA	2 to 20 mA	
Output Impedance	≤ 100 ohms	≤ 100 ohms	
Output Bias Voltage	7 to 13 VDC	7 to 13 VDC	
<b>Physical</b>			
Sensing Element	Ceramic	Ceramic	
Housing Material	Stainless Steel	Stainless Steel	
Diaphragm	316L Stainless Steel	316L Stainless Steel	
Sealing	Welded Hermetic	Welded Hermetic	
Electrical Connector	10-32 Coaxial Jack	10-32 Coaxial Jack	
Weight	0.11 oz	3.15 gm	

**OPTIONAL VERSIONS**  
Optional versions have identical specifications and accessories as listed for the standard model except where noted below. More than one option may be used.

**M** - Metric Mount  
Supplied Accessory : Model 060A24 Clamp nut M14 x 1.25-6G thd 11 mm hex 17-4 SS material (1)

**NOTES:**

- [1] For +10 volt output, minimum 24 VDC supply voltage required. Negative 10 volt output may be limited by output bias.
- [2] Zero-based, least-squares, straight line method.
- [3] See PCB Declaration of Conformance PS023 for details.

**SUPPLIED ACCESSORIES:**

- Model 060A10 Clamp nut 1/2-20-2A thd 7/16" hex (1)
- Model 065A66 Adhesive Mounting Ring (3)
- Model 160-0242-00 O-ring .250x.375(2-0100) (3)

**Pressure Sensor, ICP®, Acoustic**

Entered: <i>BLS</i>	Engineer: <i>J.P.K.</i>	Sales: <i>DPC</i>	Approved: <i>MEM</i>	Spec Number:
Date: <i>6-30-04</i>	Date: <i>7, 04</i>	Date: <i>7/6/04</i>	Date: <i>7/6/04</i>	<b>24856</b>



All specifications are at room temperature unless otherwise specified.  
In the interest of constant product improvement, we reserve the right to change specifications without notice.

ICP® is a registered trademark of PCB Group, Inc.

**PCB PIEZOTRONICS™**  
PRESSURE DIVISION  
3425 Walden Avenue, Depew, NY 14043

Phone: 716-684-0001  
Fax: 716-686-9129  
E-Mail: [pressure@pcb.com](mailto:pressure@pcb.com)

APPLICATION		
NEXT ASS'Y	USED ON	VAR

PCB Piezotronics Inc. claims proprietary rights in the information disclosed hereon. Neither it nor any reproduction thereof will be disclosed to others without written consent of PCB Piezotronics Inc.

REVISIONS					
ZONE	REV	DESCRIPTION	ECN	DATE	APP'D
	B	REVISED PER ECR	22553	11/21/03	DM 7/05

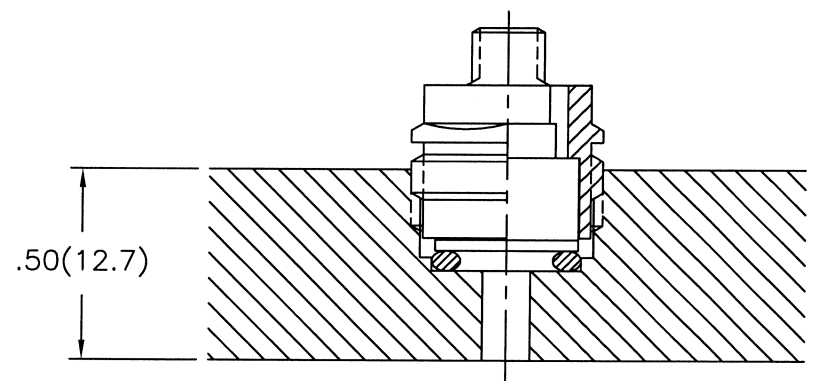
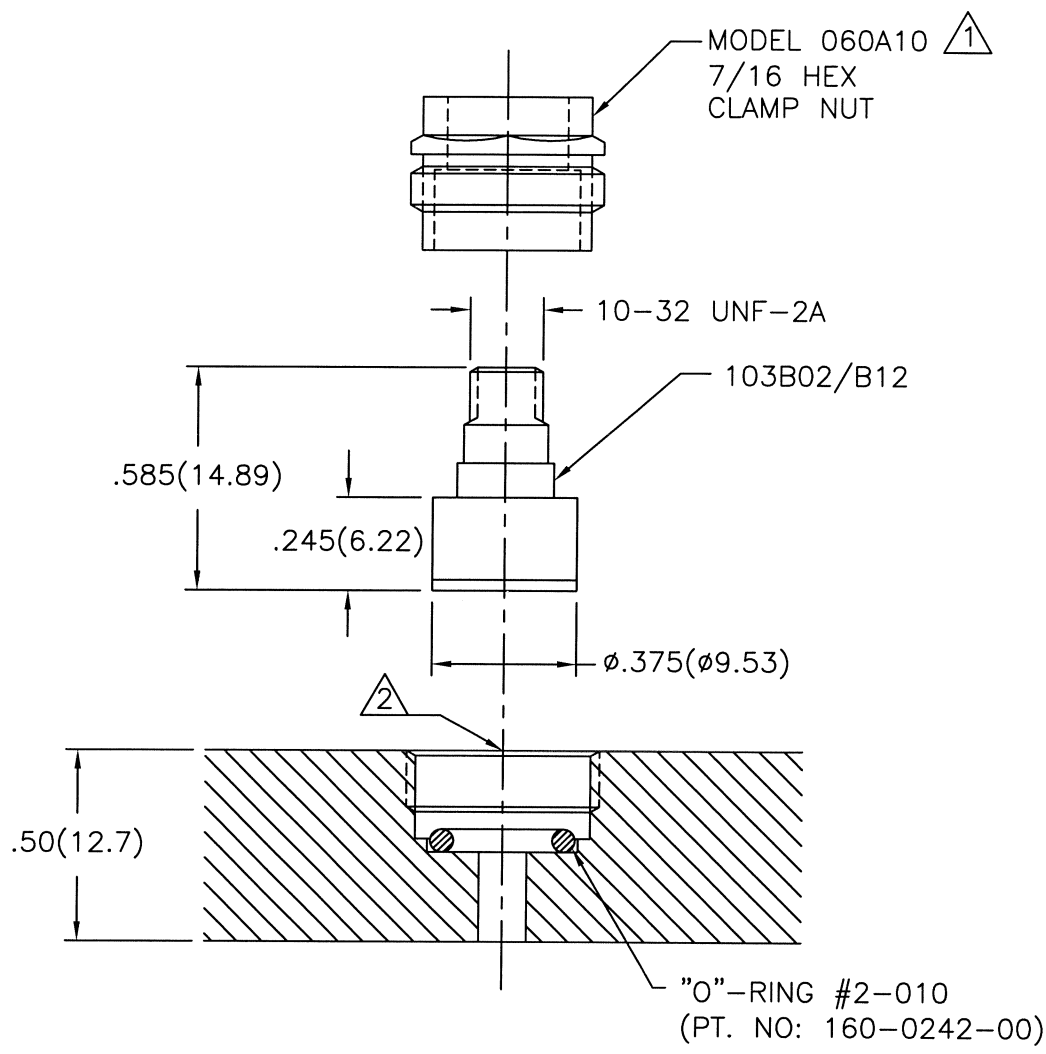

AFTER INSTALLATION

INSTALLED WITH "O" RING AS SHOWN

- △ MOUNTING HOLE PREPERATION
  - Ø.125(Ø3.18)
  - THRU
  - ┌ Ø.390(Ø9.91)
  - X .265(6.73) ▽
  - ┌ Ø.453(Ø11.51)
  - X .230(5.84) ▽
  - 1/2-20 UNF-2B
  - X .160(4.06) ▽

△ RECOMMENDED MOUNTING TORQUE IS TO BE 3-5 INCH POUNDS (.34 - .56 Nm)

UNLESS SPECIFIED TOLERANCES	
DIMENSIONS IN INCHES	DIMENSIONS IN MILLIMETERS [IN BRACKETS]
DECIMALS XX ±.01	DECIMALS X ±0.3
XXX ±.005	XX ±0.13
ANGLES ±2 DEGREES	ANGLES ±2 DEGREES
FILLETS AND RADII .003 - .005	FILLETS AND RADII [0.07 - 0.13]
DD012 REV. C 01/21/03	

DRAWN	ECR	7/22/05	MFG	KLG	7/26/05
CHK'D	DM	7/27/05	ENGR	NJL	7/22/05
APP'D	RE	7/29/05	SALES	DPC	7/26/05
TITLE					
INSTALLATION DRAWING					
MODEL 103B02, B12					
ICP PRESSURE SENSOR					

**PCB PIEZOTRONICS**  
 3425 WALDEN AVE. DEPEW, NY 14043  
 (716) 684-0001 EMAIL: SALES@PCB.COM

CODE IDENT. NO. 52681	DWG. NO. 22414
SCALE: 2X	SHEET 1 OF 3

APPLICATION		
NEXT ASS'Y	USED ON	VAR

PCB Piezotronics Inc. claims proprietary rights in the information disclosed hereon. Neither it nor any reproduction thereof will be disclosed to others without written consent of PCB Piezotronics Inc.

REVISIONS					
ZONE	REV	DESCRIPTION	ECN	DATE	APP'D
		- SEE SHEET ONE -			DM/05

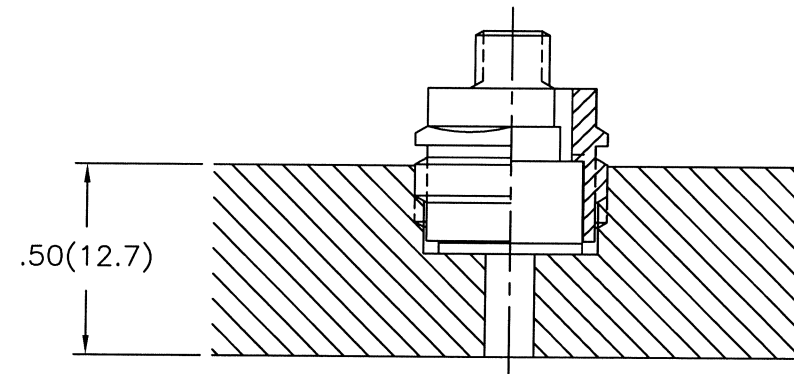
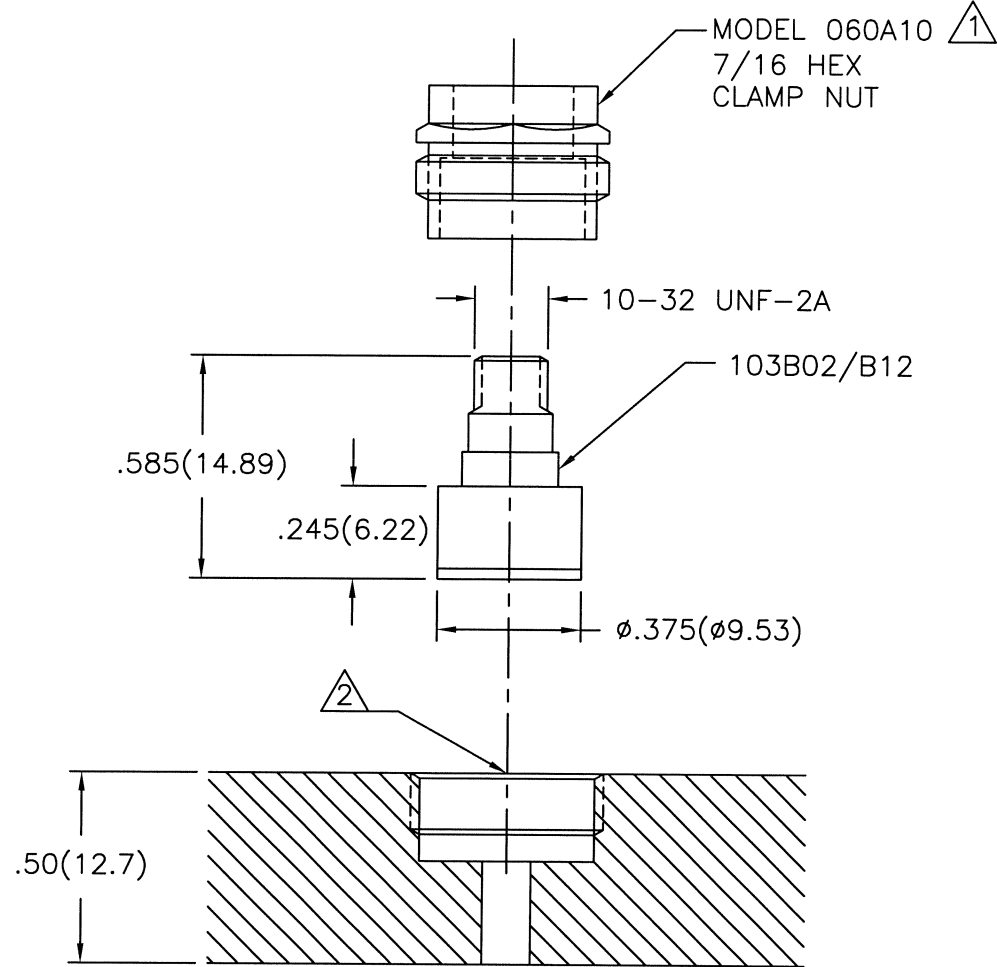

AFTER INSTALLATION

INSTALLED WITHOUT "O" RING AS SHOWN

**2** MOUNTING HOLE PREPERATION  
 φ.125(φ3.18)  
 THRU  
 □ φ.453(φ11.51)  
 X .230(5.84) ▽  
 1/2-20 UNF-2B  
 X .160(4.06) ▽

**1** RECOMMENDED MOUNTING TORQUE IS TO BE 3-5 INCH POUNDS (.34 - .56 Nm)

UNLESS SPECIFIED TOLERANCES		DRAWN		MFG		PCB PIEZOTRONICS	
DIMENSIONS IN INCHES	DIMENSIONS IN MILLIMETERS	ECR	7/22/05	KLG	7/22/05	3425 WALDEN AVE. DEPEW, NY 14043	
DECIMALS XX ±.01	[IN BRACKETS] DECIMALS X ±0.3	CHK'D	DM 7/22/05	ENGR	NJL 7/22/05	(716) 684-0001 EMAIL: SALES@PCB.COM	
XXX ±.005	XX ±0.13	APP'D	RF 7/29/05	SALES	DPC 7/29/05	CODE	DWG. NO.
ANGLES ±2 DEGREES	ANGLES ±2 DEGREES	TITLE		INSTALLATION DRAWING		IDENT. NO.	22414
FILLETS AND RADII .003 - .005	FILLETS AND RADII [0.07 - 0.13]			MODEL 103B02, B12		52681	
DD012 REV. C 01/21/03				ICP PRESSURE SENSOR		SCALE: 2X	SHEET 2 OF 3

APPLICATION		
NEXT ASS'Y	USED ON	VAR

PCB Piezotronics Inc. claims proprietary rights in the information disclosed hereon. Neither it nor any reproduction thereof will be disclosed to others without written consent of PCB Piezotronics Inc.

REVISIONS					
ZONE	REV	DESCRIPTION	ECN	DATE	APP'D
		- SEE SHEET ONE -			DM7/05

22414

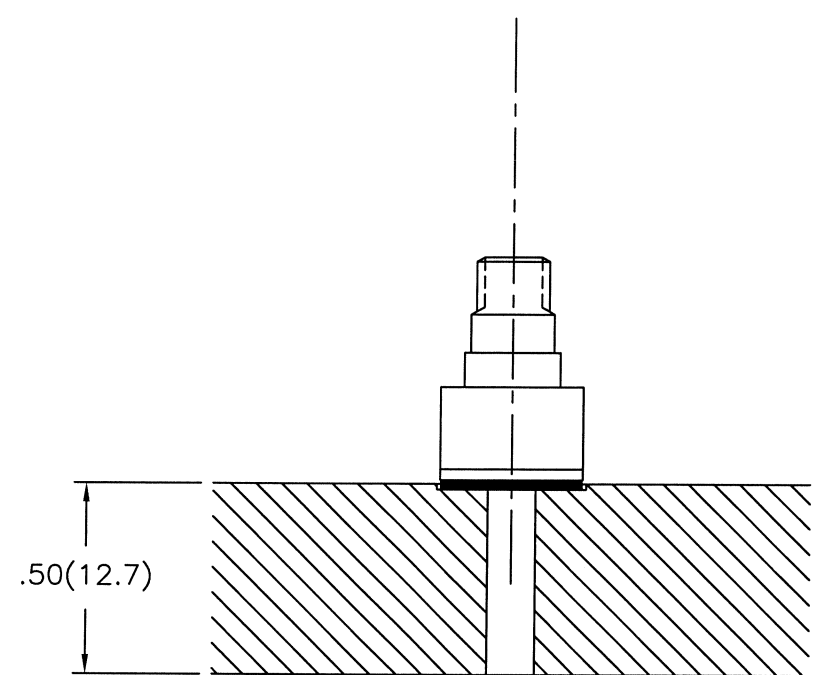
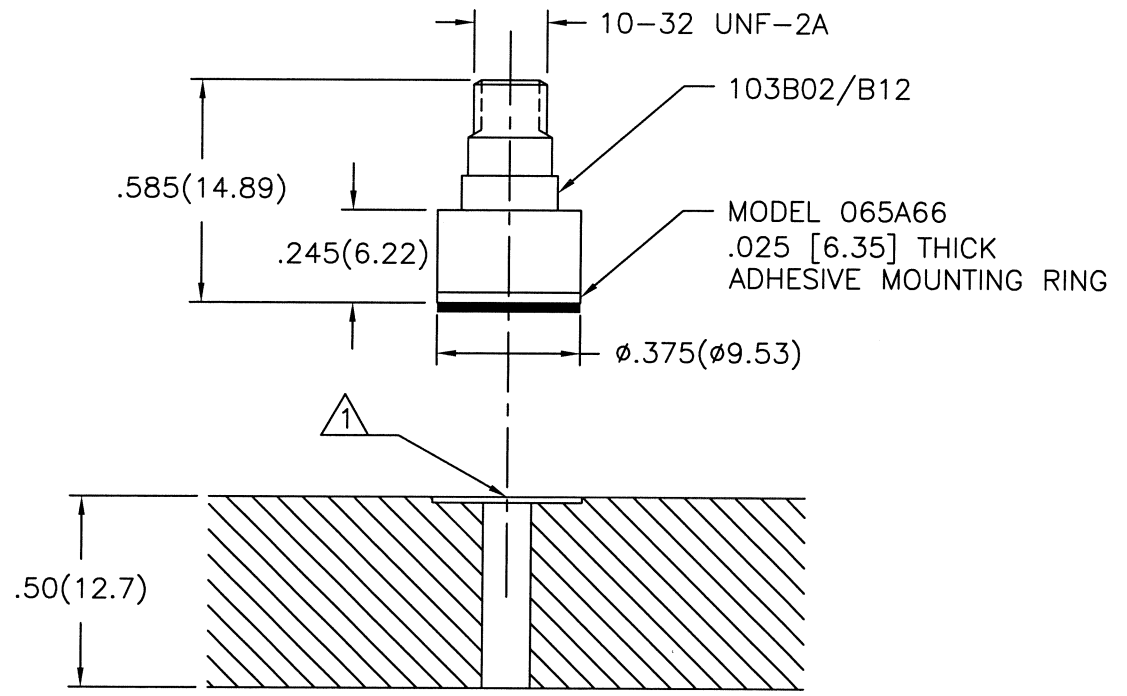

AFTER INSTALLATION

INSTALLED WITH  
ADHESIVE MOUNTING RING

▲ MOUNTING HOLE PREPERATION  
 ø.125(ø3.18)  
 THRU  
 □ ø.390(ø9.91)  
 X .015/.030(.38/.76) ▽

UNLESS SPECIFIED TOLERANCES				DRAWN		MFG		PCB PIEZOTRONICS™		
DIMENSIONS IN INCHES	DIMENSIONS IN MILLIMETERS	ECB	7/25/05	AKG	7/26/05	3425 WALDEN AVE. DEPEW, NY 14043				
DECIMALS XX ±.01	[IN BRACKETS]	CHK'D	DM	ENGR	NJL	(716) 684-0001 EMAIL: SALES@PCB.COM				
XXX ±.005	DECIMALS X ±0.3	APP'D	RE	SALES	JAC	CODE DWG. NO.				
ANGLES ±2 DEGREES	XX ±0.13	TITLE	7/29/05	7/26/05	INSTALLATION DRAWING					
FILLETS AND RADII	ANGLES ±2 DEGREES	MODEL 103B02, B12				IDENT. NO.	22414			
.003 - .005	FILLETS AND RADII	ICP PRESSURE SENSOR				52681	SCALE: 2X SHEET 3 OF 3			
	[0.07 - 0.13]	DD012 REV. C 01/21/03								