



Model 643A12

4-20 mA Output Velocity Sensor

Installation and Operating Manual

**For assistance with the operation of this product,
contact PCB Piezotronics, Inc.**

Toll-free: 800-959-4464

24-hour SensorLine: 716-684-0001

Fax: 716-684-3823

E-mail: imi@pcb.com

Web: www.imi-sensors.com



The information contained in this document supersedes all similar information that may be found elsewhere in this manual.

Total Customer Satisfaction – PCB Piezotronics guarantees Total Customer Satisfaction. If, at any time, for any reason, you are not completely satisfied with any PCB product, PCB will repair, replace, or exchange it at no charge. You may also choose to have your purchase price refunded in lieu of the repair, replacement, or exchange of the product.

Service – Due to the sophisticated nature of the sensors and associated instrumentation provided by PCB Piezotronics, user servicing or repair is not recommended and, if attempted, may void the factory warranty. Routine maintenance, such as the cleaning of electrical connectors, housings, and mounting surfaces with solutions and techniques that will not harm the physical material of construction, is acceptable. Caution should be observed to insure that liquids are not permitted to migrate into devices that are not hermetically sealed. Such devices should only be wiped with a dampened cloth and never submerged or have liquids poured upon them.

Repair – In the event that equipment becomes damaged or ceases to operate, arrangements should be made to return the equipment to PCB Piezotronics for repair. User servicing or repair is not recommended and, if attempted, may void the factory warranty.

Calibration – Routine calibration of sensors and associated instrumentation is

recommended as this helps build confidence in measurement accuracy and acquired data. Equipment calibration cycles are typically established by the users own quality regimen. When in doubt about a calibration cycle, a good “rule of thumb” is to recalibrate on an annual basis. It is also good practice to recalibrate after exposure to any severe temperature extreme, shock, load, or other environmental influence, or prior to any critical test.

PCB Piezotronics maintains an ISO-9001 certified metrology laboratory and offers calibration services, which are accredited by A2LA to ISO/IEC 17025, with full traceability to N.I.S.T. In addition to the normally supplied calibration, special testing is also available, such as: sensitivity at elevated or cryogenic temperatures, phase response, extended high or low frequency response, extended range, leak testing, hydrostatic pressure testing, and others. For information on standard recalibration services or special testing, contact your local PCB Piezotronics distributor, sales representative, or factory customer service representative.

Returning Equipment – *Following these procedures will insure that your returned materials are handled in the most expedient manner.* Before returning any equipment to PCB Piezotronics, contact your local distributor, sales representative, or factory customer service representative to obtain a Return

Materials Authorization (RMA) Number. This RMA number should be clearly marked on the outside of all package(s) and on the packing list(s) accompanying the shipment. A detailed account of the nature of the problem(s) being experienced with the equipment should also be included inside the package(s) containing any returned materials.

A Purchase Order, included with the returned materials, will expedite the turn-around of serviced equipment. It is recommended to include authorization on the Purchase Order for PCB to proceed with any repairs, as long as they do not exceed 50% of the replacement cost of the returned item(s). PCB will provide a price quotation or replacement recommendation for any item whose repair costs would exceed 50% of replacement cost, or any item that is not economically feasible to repair. For routine calibration services, the Purchase Order should include authorization to proceed and return at current pricing, which can be obtained from a factory customer service representative.

Warranty – All equipment and repair services provided by PCB Piezotronics, Inc. are covered by a limited warranty against defective material and workmanship for a period of one year from date of original purchase. Contact

PCB for a complete statement of our warranty. Expendable items, such as batteries and mounting hardware, are not covered by warranty. Mechanical damage to equipment due to improper use is not covered by warranty. Electronic circuitry failure caused by the introduction of unregulated or improper excitation power or electrostatic discharge is not covered by warranty.

Contact Information – International customers should direct all inquiries to their local distributor or sales office. A complete list of distributors and offices can be found at www.pcb.com. Customers within the United States may contact their local sales representative or a factory customer service representative. A complete list of sales representatives can be found at www.pcb.com. Toll-free telephone numbers for a factory customer service representative, in the division responsible for this product, can be found on the title page at the front of this manual. Our ship to address and general contact numbers are:

PCB Piezotronics, Inc.
3425 Walden Ave.
Depew, NY 14043 USA
Toll-free: (800) 828-8840
24-hour SensorLineSM: (716) 684-0001
Website: www.pcb.com
E-mail: info@pcb.com



Model 642/643/647/648 A Series Industrial 4-20mA Sensor

CE



SENSORS AND INSTRUMENTATION FOR MACHINE CONDITION MONITORING

Operating Guide with Enclosed Warranty Information

3425 Walden Avenue, Depew, New York 14043-2495

Phone (716) 684-0003

Fax (716) 684-3823

Toll Free Line 1-800-959-4IMI

***MANUAL NUMBER: 25778
MANUAL REVISION: C
ECN NUMBER: xxxxx***



Table of Contents

Introduction..... Page 3
 General Features

Dimension Drawing..... Page 4

Operation and Wiring..... Page 5
 Standard Wiring
 Taking Measurements
 RV Option
 TO Option

Installation..... Page 9

ESD Sensitivity Page 10

Warranty/Serviceing

Warranty, Service & Return Procedure..... Page 11

Customer Service Page 12



Introduction

The Model 642/643/647/648 A Series Industrial 4-20mA Sensors combine the capabilities of a piezoelectric vibration sensor and a 4-20mA vibration transmitter. The sensor outputs a 4-20mA signal that is proportional to the overall velocity or acceleration of the machinery. Ideal for monitoring the vibration of process equipment such as fans, motors and pumps, the output of the sensor is used for process control or predictive maintenance. There are many options in this series. Please refer to specific specification sheets for further details.

General Features

- Imbedded Piezoelectric Accelerometer for improved accuracy and frequency response.
- Vibration range can be in Acceleration or Velocity.
- Allows for continuous vibration monitoring of critical applications.
- Reduces sophisticated vibration analysis requirements.
- RV (Raw Vibration) option for conducting frequency analysis and machinery diagnostics.
- TO (Temperature Output) option via an independent 4-20mA loop.
- Readily interfaces to existing process control and predictive maintenance equipment.
- Rugged stainless steel construction for applications in harsh environments.
- Flexible design allows for various custom requirements.
- Swivel mount simplifies installation.
- Cable may be positioned in any direction.

Dimension Drawing

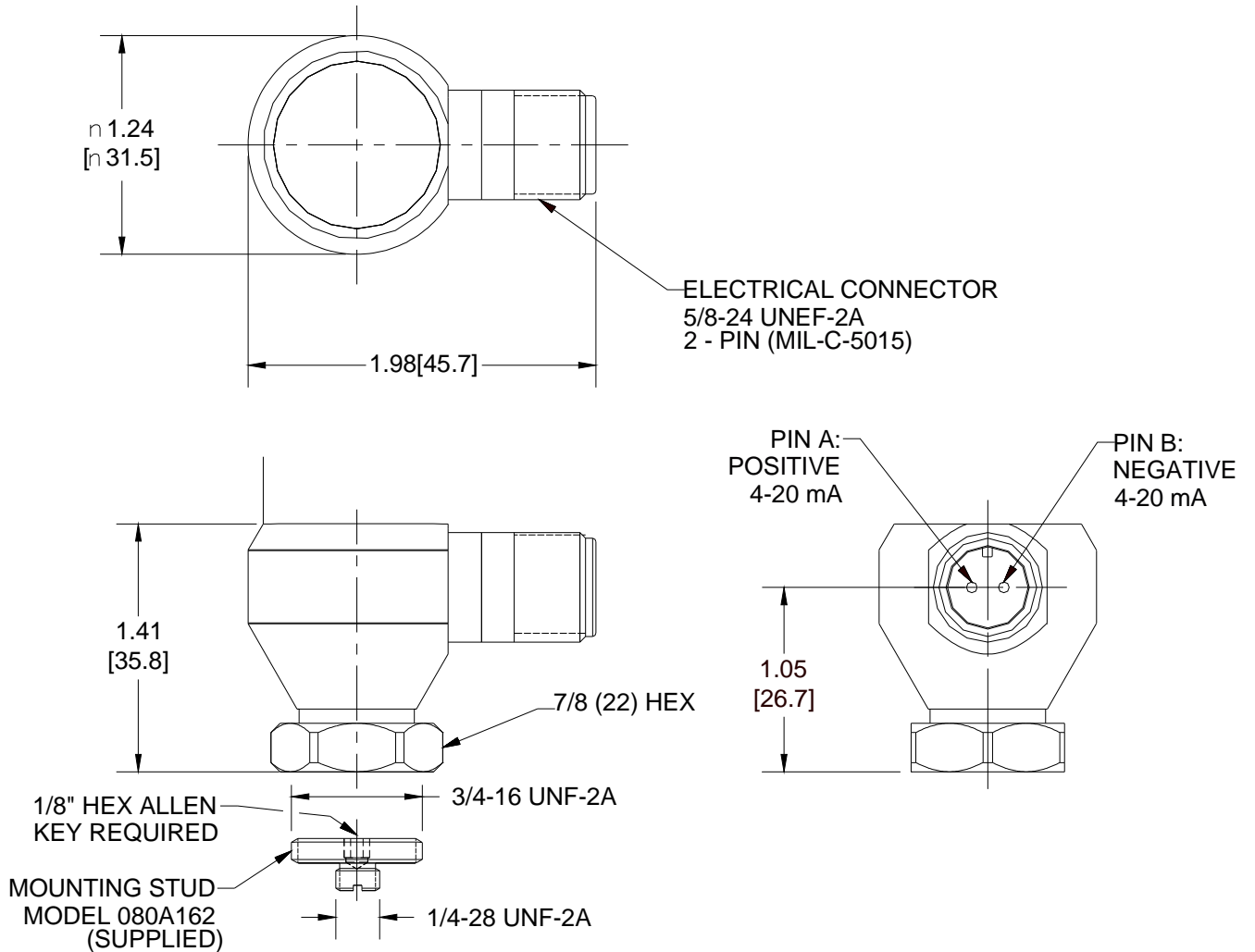

Inch (mm)

Operation and Wiring

Standard Wiring

The Model 642/643/647/648 A Series operates from a standard 2-wire, 4-20mA loop. If using a loop powered unit, attach the positive (+) input from the power supply to Pin A or **Red** wire on the sensor and the negative (-) input from the power supply to Pin B or **Blue** wire of the sensor.

Figure 1 – wiring: loop powered

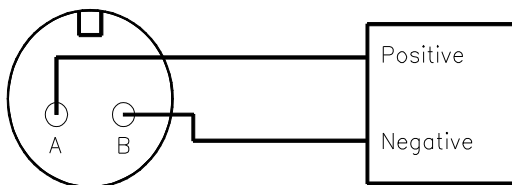
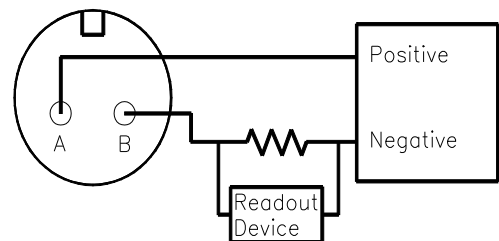

Figure 2 – wiring: loop powered/DC source



If using a standard DC power supply, install either an ammeter and/or load resistor in line with the output, Pin B or **Blue** wire.

The resistor will generate a DC voltage that is proportional to current by:

$$V = IR$$

If $R = 500$ ohms and $I = 6$ mA, then $V = 3$ VDC

Note:

- Resistor value must be less than: $(V_{\text{supply}} - 12) \times 50$.
- For integral cable sensors: RED wire is positive, BLUE wire is negative.

Taking Measurements

When measuring the current output from the unit, use the following formula to calculate the vibration level:

$$\text{Vibration Output} = (\text{Measured Output} - 4\text{mA}) \times (\text{Full Scale Vibration Output} / 16\text{mA})$$

| <u>Measured mA</u> | <u>642AX0</u> | <u>642AX1</u> | <u>642AX2</u> |
|--------------------|---------------|---------------|---------------|
| 4.00 | 0.0 ips, pk | 0.0 ips, pk | 0.0 ips, pk |
| 8.00 | 0.125 ips, pk | 0.25 ips, pk | 0.5 ips, pk |
| 12.0 | 0.25 ips, pk | 0.5 ips, pk | 1.0 ips, pk |
| 15.75 | 0.37 ips, pk | 0.73 ips, pk | 1.47 ips, pk |
| 20 | 0.5 ips, pk | 1.0 ips, pk | 2.0 ips, pk |

| <u>Measured mA</u> | <u>643AX0</u> | <u>643AX1</u> | <u>643AX2</u> |
|--------------------|----------------|---------------|---------------|
| 4.00 | 0.0 ips, rms | 0.0 ips, rms | 0.0 ips, rms |
| 8.00 | 0.125 ips, rms | 0.25 ips, rms | 0.5 ips, rms |
| 12.0 | 0.25 ips, rms | 0.5 ips, rms | 1.0 ips, rms |
| 15.75 | 0.37 ips, rms | 0.73 ips, rms | 1.47 ips, rms |
| 20 | 0.5 ips, rms | 1.0 ips, rms | 2.0 ips, rms |

| <u>Measured mA</u> | <u>647</u> | <u>648</u> |
|--------------------|------------|------------|
| 4.00 | 0.0 g rms | 0.0 g rms |
| 8.00 | 1.25 g rms | 2.50 g rms |
| 12.0 | 2.50 g rms | 5.00 g rms |
| 15.75 | 3.67 g rms | 7.34 g rms |
| 20 | 5.00 g rms | 10.0 g rms |

RV Option

The RV (raw vibration) option includes a 100mV/g $\pm 20\%$ additional output. The accelerometer frequency range is 1 Hz-10 kHz, maximum amplitude of 15 g-pk. Data collectors or analyzers can use this vibration signal for further analysis.

Figure 3 – RV wiring

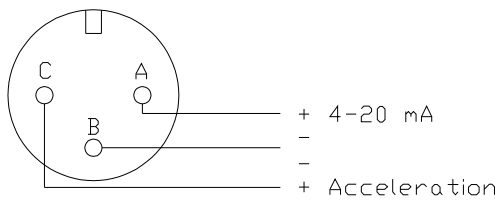

For integral cable sensors:

| | |
|--------------|--|
| RED | 4-20mA Positive |
| BLACK | 4-20mA Negative (same as green) |
| GREEN | -RV Acceleration Negative (same as black) |
| WHITE | +RV Acceleration Positive |

Note:

- The Acceleration Signal Negative has to be isolated from any grounding. If this terminal is grounded, the 4-20mA loop will short, causing no output.
- The acceleration output signal is ideally suited for use with portable battery powered data collectors or analyzers.

TO Option

The TO (Temperature Output) option includes an additional independent 4-20mA output for temperature measurement. The temperature range is from -40°C to 125°C with an overall accuracy of $\pm 5\%$ FSO. The imbedded temperature sensor monitors the environment internal to the sensor housing and is situated at approximately mid level.

Figure 4 – TO wiring

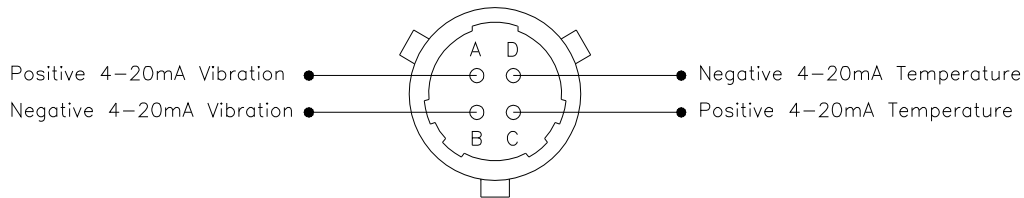

For integral cable sensors:

| | |
|--------------|------------------------------------|
| RED | 4-20mA Vibration Positive |
| BLACK | 4-20mA Vibration Negative |
| GREEN | 4-20mA Temperature Negative |
| WHITE | 4-20mA Temperature Positive |

Note:

- The same power supply can be used for both 4-20mA loops. Connect the both positive terminals directly to the power supply, then use the negative terminals for independent process loops.

Installation

Installation should be performed per the following detail drawing for best performance.

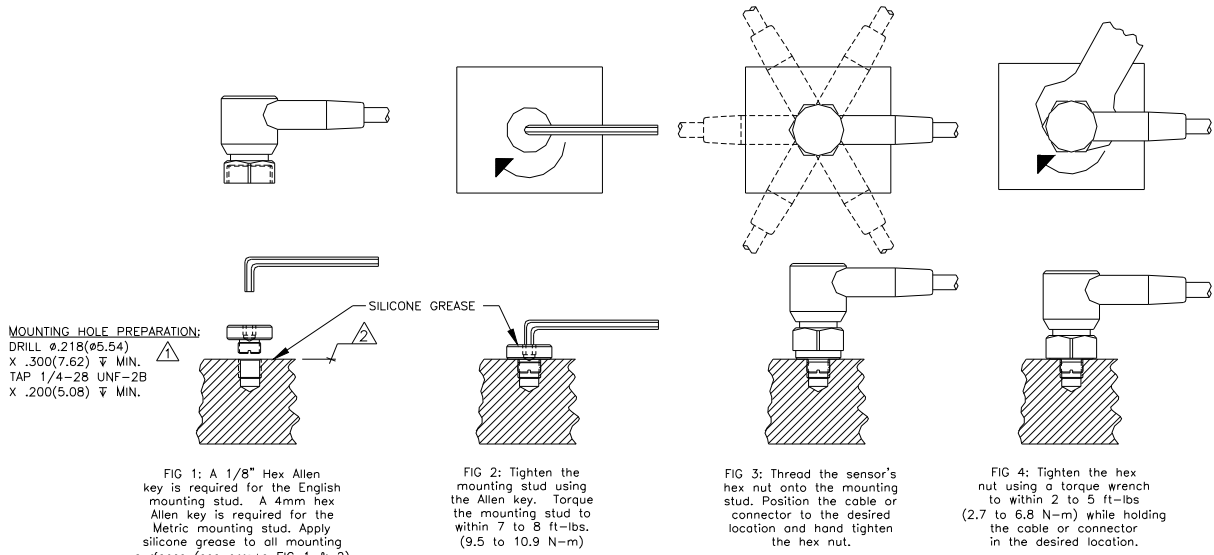

3.) FOR BEST RESULTS, PLACE A THIN LAYER OF SILICONE GREASE (DOW CORNING #4 OR EQUIVALENT) ON INTERFACE PRIOR TO MOUNTING.

∇ MOUNTING SURFACE SHOULD BE FLAT TO WITHIN .001(0.03) TIR WITH A MINIMUM 63/(1.6) FINISH FOR BEST RESULTS.

\triangle DRILL PERPENDICULAR TO MOUNTING SURFACE TO WITHIN $\pm 1^\circ$

Warning 1 – ESD sensitivity

The power supply/signal conditioner should not be opened by anyone other than qualified service personnel. This product is intended for use by qualified personnel who recognize shock hazards and are familiar with the safety precautions required to avoid injury.

Warning 2 – ESD sensitivity

This equipment is designed with user safety in mind; however, the protection provided by the equipment may be impaired if the equipment is used in a manner not specified by PCB Piezotronics, Inc.

Caution 1 – ESD sensitivity

Cables can kill your equipment. High voltage electrostatic discharge (ESD) can damage electrical devices. Similar to a capacitor, a cable can hold a charge caused by triboelectric transfer, such as that which occurs in the following:

- *Laying on and moving across a rug,*
- *Any movement through air,*
- *The action of rolling out a cable, and/or*
- *Contact with a non-grounded person.*

The PCB solution for product safety:

- *Connect the cables only with the AC power off.*
- *Temporarily “short” the end of the cable before attaching it to any signal input or output.*

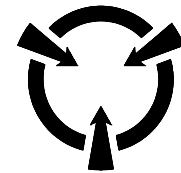

CAUTION
ELECTROSTATIC
DISCHARGE SENSITIVE

Caution 2 – ESD sensitivity

ESD considerations should be made prior to performing any internal adjustments on the equipment. Any piece of electronic equipment is vulnerable to ESD when opened for adjustments. Internal adjustments should therefore be done ONLY at an ESD-safe work area. Many products have ESD protection, but the level of protection may be exceeded by extremely high voltage.



Warranty

IMI instrumentation is warranted against defective material and workmanship for 1 year unless otherwise expressly specified. Damage to instruments caused by incorrect power or misapplication, is not covered by warranty. *If there are any questions regarding power, intended application, or general usage, please consult with your local sales contact or distributor.* Batteries and other expendable hardware items are not covered by warranty.

Service

Because of the sophisticated nature of IMI instrumentation, field repair is typically **NOT** recommended and may void any warranty. If factory service is required, return the instrumentation according to the "Return Procedure" stated below. *A repair and/or replacement quotation will be provided prior to servicing at no charge.* Before returning the unit, please consult a factory IMI applications engineer concerning the situation as certain problems can often be corrected with simple on-site procedures.

Return procedure

To expedite returned instrumentation, contact a factory IMI applications engineer for a RETURN MATERIAL AUTHORIZATION (RMA) NUMBER. Please have information available such as model and serial number. Also, to insure efficient service, provide a written description of the symptoms and problems with the equipment to a local sales representative or distributor, or contact IMI if none are located in your area.

Customers outside the U.S. should consult their local IMI distributor for information on returning equipment. For exceptions, please contact the International Sales department at IMI to request shipping instructions and an RMA. For assistance, please call (716) 684-0003, or fax us at (716) 684-3823. You may also receive assistance via e-mail at imi@pcb.com or visit our web site at www.pcb.com.



Customer Service

IMI, a division of PCB Piezotronics, guarantees **Total Customer Satisfaction**. If, at any time, for any reason, you are not completely satisfied with any IMI product, IMI will repair, replace, or exchange it at no charge. You may also choose to have your purchase price refunded.

IMI offers to all customers, at no charge, 24-hour phone support. This service makes product or application support available to our customers, day or night, seven days a week. When unforeseen problems or emergency situations arise, call the **IMI Hot Line at (716) 684-0003**, and an application specialist will assist you.



3425 Walden Avenue, Depew, NY 14043-2495
Phone: (716) 684-0003 • USA Fax: (716) 684-3823 • INTL Fax: (716) 684-4703

*ICP® is a registered trademark of PCB Group, Incorporated,
which uniquely identifies PCB sensors that incorporate built-in microelectronics.*

Model Number

643A12

LOOP POWERED CURRENT OUTPUT SENSOR

Revision: B

ECN #: 20329

| | ENGLISH | SI | |
|------------------------------------|-----------------------|-----------------------|--------|
| Performance | | | |
| Measurement Range | 0.0 to 2 in/s rms | 0 to 50.8 mm/s rms | [1] |
| Output | 4-20 mA | 4-20 mA | |
| Frequency Range ($\pm 10\%$) | 600 to 60,000 cpm | 10 Hz to 1 kHz | [2][3] |
| Broadband Resolution | 0.005 in/s rms | 0.13 mm/s rms | [4] |
| Non-Linearity | $\pm 1\%$ | $\pm 1\%$ | |
| Environmental | | | |
| Temperature Range | -40 to 185 °F | -40 to 85 °C | |
| Electrical | | | |
| Excitation Voltage | 12 to 30 VDC | 12 to 30 VDC | |
| Load Resistance | 50 (Vs-12) ohms | 50 (Vs-12) ohms | |
| Settling Time (within 2% of value) | <15 sec | <15 sec | |
| Electrical Isolation (Case) | >10 ⁸ ohms | >10 ⁸ ohms | |
| Physical | | | |
| Size (Hex x Height) | 7/8 in x 1.41 in | 22.2 mm x 35.8 mm | |
| Weight (without cable) | 3.8 oz | 108 gm | |
| Mounting Thread | 1/4-28 UNF | Not Applicable | |
| Mounting Torque | 3 to 5 ft-lb | 4 to 7 N-m | |
| Sensing Element | Ceramic | Ceramic | |
| Sensing Geometry | Shear | Shear | |
| Housing Material | Stainless Steel | Stainless Steel | |
| Sealing | Welded Hermetic | Welded Hermetic | |
| Electrical Connector | Integral Cable | Integral Cable | |
| Electrical Connection Position | Side | Side | |
| Cable Termination | Pigtail Ends | Pigtail Ends | |
| Electrical Connections (Red) | 4-20 mA Pos | 4-20 mA Pos | |
| Electrical Connections (Blue) | 4-20 mA Neg | 4-20 mA Neg | |
| Cable Length | 10 ft | 3.0 m | |
| Cable Type | Polyurethane | Polyurethane | |



All specifications are at room temperature unless otherwise specified.
In the interest of constant product improvement, we reserve the right to change specifications without notice.

ICP® is a registered trademark of PCB Group, Inc.

OPTIONAL VERSIONS

Optional versions have identical specifications and accessories as listed for the standard model except where noted below. More than one option may be used.

M - Metric Mount

Supplied Accessory : Model M080A163 Mounting pad 3/4-16 to M6 x 1 (for Models 607A01 and 608A11) replaces Model 080A162

RV - Buffered Analog Signal Output - 100 mV/g ($\pm 20\%$)

| Electrical Connector | Integral Cable | Integral Cable |
|--------------------------------|-------------------|-------------------|
| Electrical Connections (Red) | 4-20 mA Pos | 4-20 mA Pos |
| Electrical Connections (Black) | 4-20 mA Neg | 4-20 mA Neg |
| Electrical Connections (White) | Signal Output Pos | Signal Output Pos |
| Electrical Connections (Green) | Signal Output Neg | Signal Output Neg |

NOTES:

- [1] Conversion Factor 1 in/sec = 0.0254 m/sec.
 [2] 1Hz = 60 cpm (cycles per minute).
 [3] Current will fluctuate at frequencies below 5 Hz.
 [4] Typical value.
 [5] See PCB Declaration of Conformance PS039 for details.

SUPPLIED ACCESSORIES:

Model 080A162 Mounting Stud (1)
 Model ICS-4 NIST-traceable single-axis amplitude response calibration from 0 cpm (0 Hz) to upper 10% frequency for 4 - 20 mA output vibration sensor

Loop Powered Current Output Vibration Sensor

| | | | | |
|---------------------|----------------------|---------------------|---------------------|--------------|
| Entered: <i>TR</i> | Engineer: <i>MJE</i> | Sales: <i>EST</i> | Approved: <i>UR</i> | Spec Number: |
| Date: <i>8-3-04</i> | Date: <i>8/3/04</i> | Date: <i>8/3/04</i> | Date: <i>8/1/04</i> | 25776 |

IMI SENSORS
 A PCB PIEZOTRONICS DIV.
 3425 Walden Avenue, Depew, NY 14043

Phone: 800-959-4464
 Fax: 716-684-3823
 E-Mail: imi@pcb.com

25777

PCB Piezotronics Inc. claims proprietary rights in the information disclosed herein. Neither it nor any reproduction thereof will be disclosed to others without written consent of PCB Piezotronics Inc.

| APPLICATION | | |
|-------------|---------|-----|
| NEXT ASS'Y | USED ON | VAR |
| | | |

| REVISIONS | | | | |
|-----------|----------------------|-------|---------|-----------|
| REV | DESCRIPTION | ECN | DATE | APP'D |
| NR | RELEASED TO DRAFTING | | 4/26/04 | |
| A | REVISED PER ECN | 21205 | 12/7/04 | <i>DM</i> |

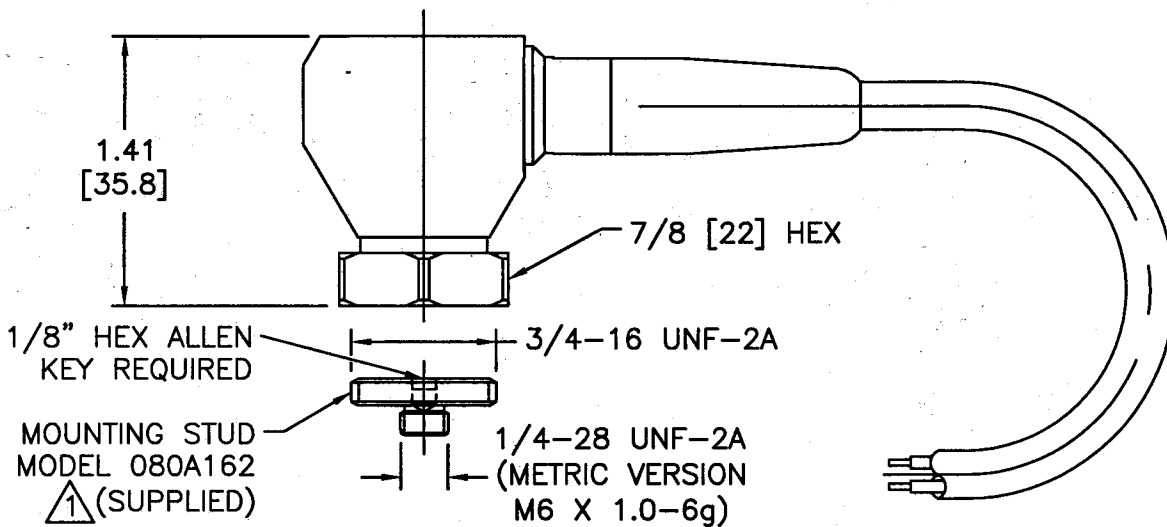
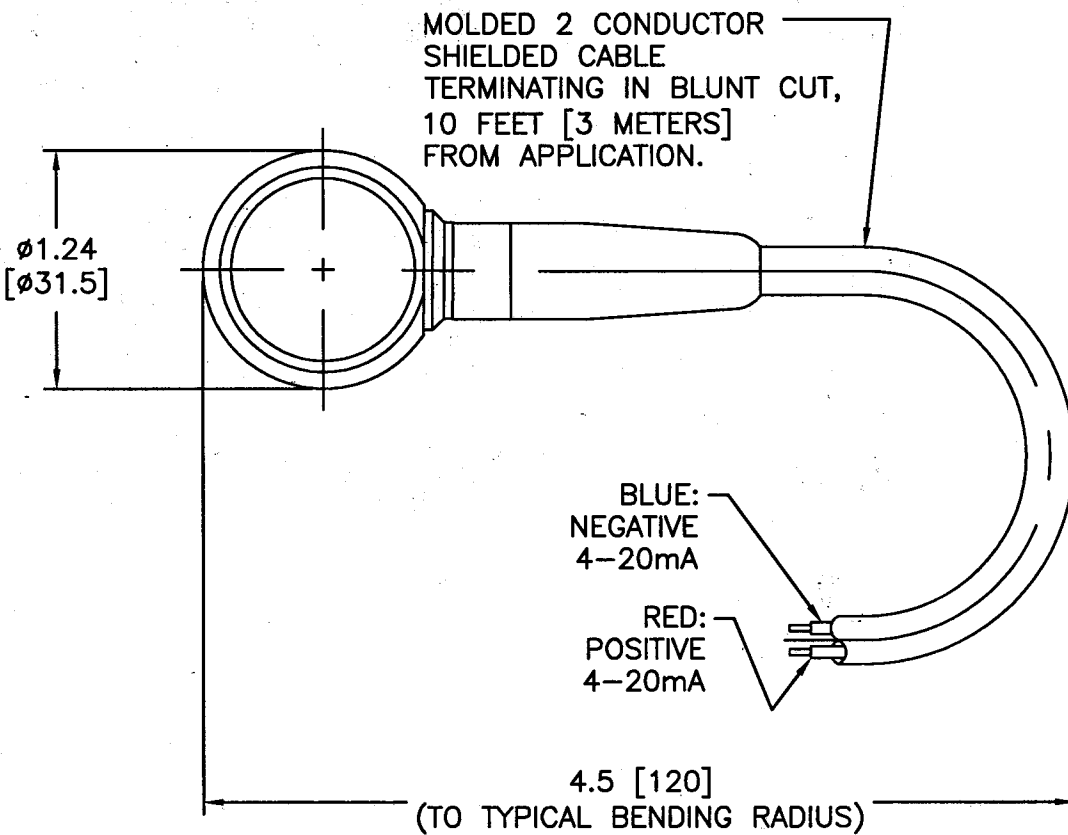

▲ FOR METRIC ACCELEROMETER (M642A1X, M643A1X, M647A1X, M648A1X), MOUNTING STUD MODEL M080A163 REPLACES 080A162.

| UNLESS SPECIFIED: TOLERANCES | | DRAWN | CHK'D | APP'D | MFG | ENGR | SALES | PCB PIEZOTRONICS™ | | |
|-------------------------------|---------------------------------|--|-----------|-------------|----------------|----------------|--------------------------|---|----------|--|
| DIMENSIONS IN INCHES | DIMENSIONS IN MILLIMETERS | <i>RCE</i> | <i>DM</i> | <i>U.R.</i> | <i>12/8/04</i> | <i>12/8/04</i> | <i>12/8/04</i> | 3425 WALDEN AVE. DEPEW, NY 14043 (716) 684-0001 EMAIL: SALES@PCB.COM | | |
| DECIMALS XX ±.01 | [IN BRACKETS] DECIMALS X ±0.3 | | | | | | | CODE IDENT. NO. | DWG. NO. | |
| XXX ±.005 | XX ±0.13 | | | | | | | 52681 | 25777 | |
| ANGLES ±2 DEGREES | ANGLES ±2 DEGREES | TITLE: OUTLINE DRAWING MODEL 642A1X, M, 643A1X, M, 647A1X, M, 648A1X, M | | | | | SCALE: FULL SHEET 1 OF 1 | | | |
| FILLETS AND RADII .003 - .005 | FILLETS AND RADII [0.07 - 0.13] | DD011 REV. C 01/21/03 | | | | | | | | |